

# ALA

ФЕРРУЧЧО ЛАВИАНИ



Стол Ala , в котором сочетаются креативность и мастерство, является доминирующим присутствием в гостиной - местом для повседневной домашней жизни. Круглая или полуовальная столешница, очерченная границей, отрывающей край от толщины, кажется подвешенной в воздухе, почти готова к полету. Конические ножки только усиливают этот эффект, исходя из конструкции крыльев самолета.

## ТИП / ТАБЛИЦЫ

## ТЕХНИЧЕСКОЕ ОПИСАНИЕ

*Новая платформа обогащает коллекцию столов Ala длиной 3100 мм.*

*Стол с деревянным основанием из шпона или матового лака. Формованный верх доступен в двух вариантах: овальный верх доступен в мраморном верхе во всех вариантах или из прозрачного стекла; круглая верхняя часть из литого мрамора, а верх из литой древесины с той же отделкой, что и основа. Для круглой вершины доступна дополнительная вращающаяся литая верхняя часть из мрамора (Lazy Susan), доступна в двух измерениях.*

**MisuraEmme®**

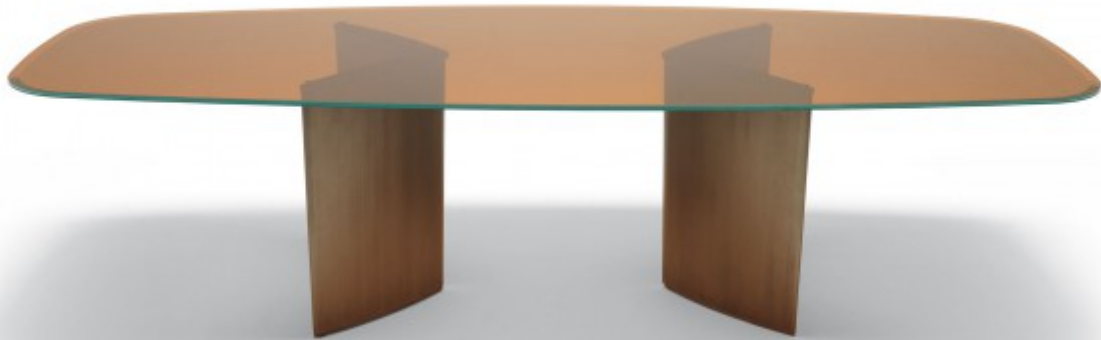

## ДИЗАЙНЕР ФЕРРУЧЧО ЛАВИАНИ

Born in Cremona in 1960 Laviani attends the Istituto Professionale Internazionale per l'Artigianato Liutario e del Legno di Cremona, receiving his degree in 1978. He later attends the Faculty of Architecture, at the Politecnico di Milano where he graduates in 1986, while attending at the same time the Scuola Politecnica di Design in Milan from 1982 to 1984. In 1983 he starts working for Michele De Lucchi; he becomes a partner in 1986 and works there until 1991, when he decides to open his own studio in Milan. Laviani's work mainly focuses on product design, interior design, art direction and graphic. Since 1991, he is the Art Director for Kartell; same role he has played for other companies. He designs retail spaces and set-ups, offices and houses for private clients, as well as for furniture and fashion. In 2008 an exhibition was dedicated to the lamps he designed for Kartell. Bourgie and Take lamps for Kartell are part of the permanent Collection of IMA, *Indianapolis Museum of Art (USA)*; also other products have been featured in museums and shows all over the world. In 2015, Laviani develops the new concept for Kartell Museum in Noviglio, updating the interior design he had conceived in 1999, when he received the award Premio Guggenheim Impresa & Cultura 2000, as the best museum of a company. Last year, he has started a collaboration with the Italian mosaic brand Bisazza. In 2016 Ferruccio has designed the pop-up store for the fashion designer Paula Cademartori and the set-up for the Haute Couture Women show for Dolce e Gabbana, at Laboratori Ansaldo, Teatro alla Scala, Milan.



**MisuraEmme®**

# TOP FINISHINGS

## TRANSPARENT GLASS

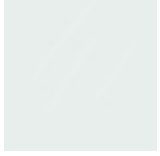

V00  
Naturale



V05 Fumé



V01 Bronzo

## MARBLES



BC Bianco  
Carrara Matt

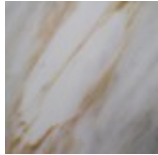

CA Calacatta  
Oro Matt

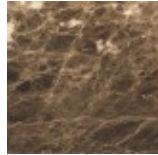

EM  
Emperador  
Matt



TV  
Travertino  
Matt



BA Basaltite  
Matt

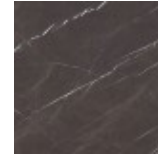

GT Grey  
Stone Glossy

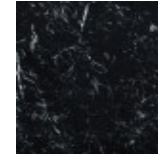

MR  
Marquinia  
Glossy

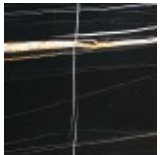

SR Sahara  
Noir Glossy

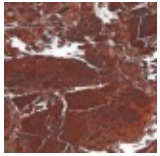

RL Rosso  
Lepanto



OR Orobico

# BASE / UNDERTOP FINISHINGS

## MATT LACQUERED COLOURS



## MATT LACQUERED ANTIQUE BRASS COLOURS



7R Ottone  
Anticato



5R Dark  
Bronze  
Anticato



6R Graphite  
Anticato

## MATT VENEERS



52 Rovere  
fumé

# DIMENSIONS

## Glass top

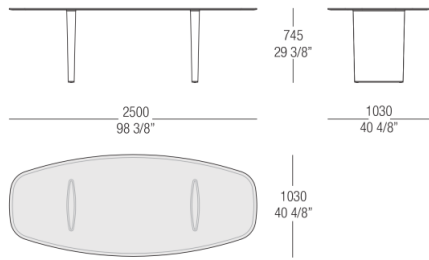

## Glass top

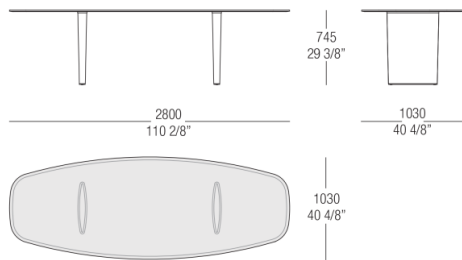

## Glass top

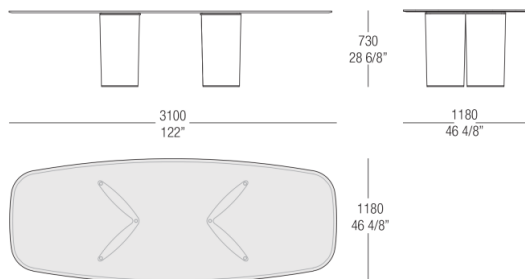

Marble top

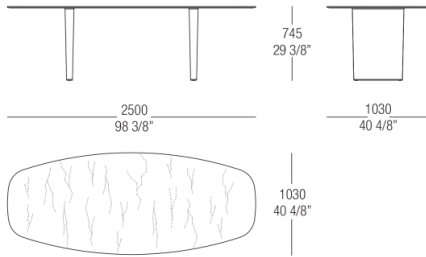

Marble top

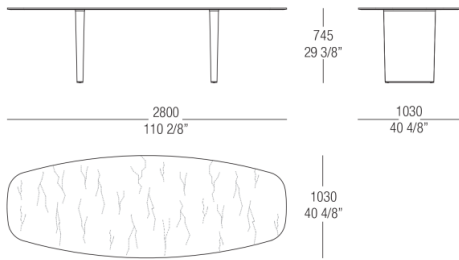

Marble top

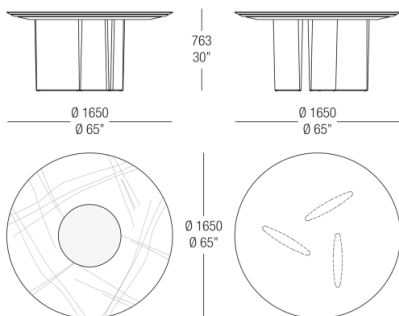

Marble top

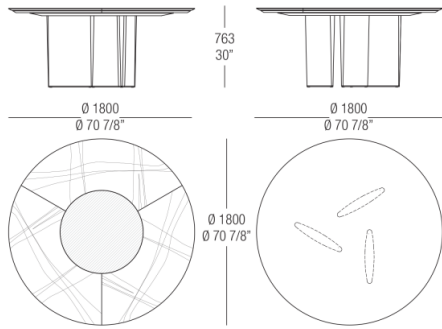

Marble top

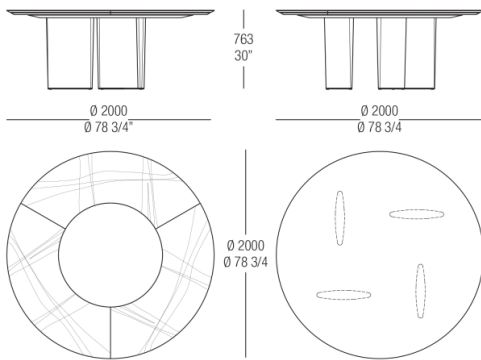

Marble top

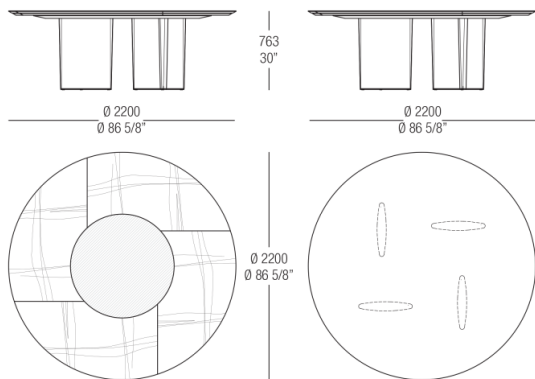



Marble top

