

GRAMERCY

MAURO LIPPARINI



Gramercy is a delicate object with a gentle silhouette, designed to bring taste and modernity to the living area. The tapered semi-oval top rests on an elegant, simple structure in solid oak with artisanal finishes. The whole piece is an exercise in balance between levity and solidity – the former is provided by unassuming, sleek legs, the latter by the central join that ensures stability for the structure.

TYPE / TABLES

TECHNICAL DESCRIPTION

Fixed table available in 2 dimensions.

Base with hand crafted solid stained oak.

Cylindrical spacers in satined steel.

Semi-oval shaped top available in the finish:

- W. 2400 mm (94 4/8")
- transparent glass th. 12mm.
- W. 2650 mm (104 3/8")
- transparent glass th. 12mm.
- wood top with shaped under top available in the finishes:
 - veneered wood top and undertop in matt lacquer
 - veneered wood top and undertop in glossy lacquer

MisuraEmme®

- *top and undertop in matt lacquer same colour*
- *top and undertop in glossy lacquer same colour*
- *two colour: top and undertop in glossy lacquer in two different colours.*

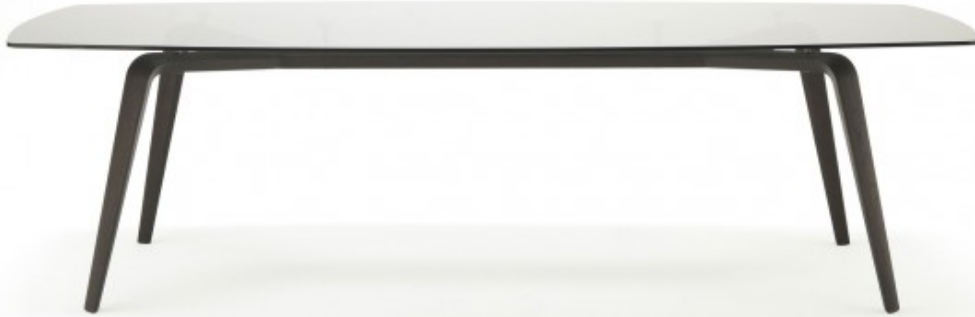

DESIGNER

MAURO LIPPARINI

Mauro Lipparini earned a degree in Architecture in 1980 from Università degli Studi of Florence, where he also worked as a professor. He won the international design contests Young & Designer Milan (1987) and International Du Pont Award Köln (Germany, 1988 and 1989). Lipparini's intense activity in the field of industrial design covers office and home furniture, the textile industry and other products created for many companies in Europe and Japan. In architecture and interior design, Lipparini has concentrated mainly on private and public housing, on showrooms, retail sales outlets and exposition installations. Furthermore, Lipparini also designs and realizes advanced corporate identity image systems that range from graphics to editorial services to production. Lipparini's style is based on the essential shapes and the clear and decisive lines that are characteristic of natural minimalism. His creations are imbued with a joyful spirit and with an elating sense of aesthetic pleasure and creativity. Thanks to his free use of color, organic weave patterns and original visual ideas, Lipparini amplifies the palette of minimalism, conveying the spontaneity and power of this aesthetic style and projecting it towards a new era of great maturity and wellbeing.



TOP FINISHINGS

MATT LACQUERED COLOURS



HIGH GLOSS LACQUERED COLORS



L01 Gesso



L8B Caolino



L9G Ostrica



L6B Grigio
Pietra



L14 Nero

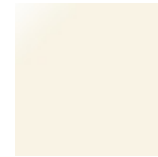

L02 Talco



L9F Sand



L4G Argilla



L8C
Cappuccino



L5B Grigio
Lava



L72 Sabbia



L8A Beige



L9T Toffee



L93 Melange



L13 Sepia

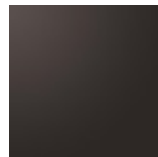

L09 Wengè



L98 Oliva



L8S Giallo



L9B Senape



L94 Marsala



L81 Fuoco



L95 Ruggine



L9H Petrolio



L9E Deep
Blu

TRANSPARENT GLASS

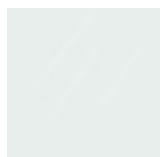

V00
Naturale



V05 Fumé

MATT VENEERS

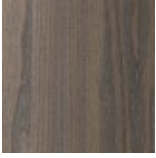

53 Olmo
grey

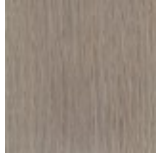

50 Rovere
cenere



52 Rovere
fumé

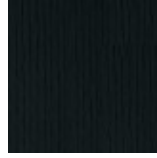

51 Oak Black

UNDERTOP FINISHINGS (WOOD TOP ONLY)

MATT LACQUERED COLOURS



HIGH GLOSS LACQUERED COLORS



L01 Gesso



L8B Caolino



L9G Ostrica



L6B Grigio
Pietra



L14 Nero

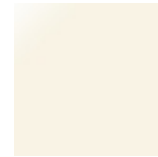

L02 Talco



L9F Sand



L4G Argilla

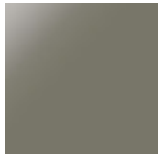

L8C
Cappuccino



L5B Grigio
Lava



L72 Sabbia



L8A Beige



L9T Toffee



L93 Melange



L13 Sepia

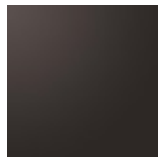

L09 Wengè



L98 Oliva



L8S Giallo



L9B Senape



L94 Marsala



L81 Fuoco



L95 Ruggine



L9H Petrolio



L9E Deep
Blu

BASE FINISHINGS

MATT VENEERS

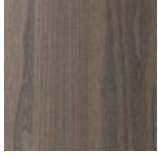

53 Olmo
grey



50 Rovere
cenere



52 Rovere
fumé

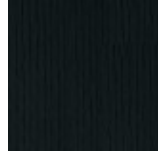

51 Oak Black

DIMENSIONS

Glass top

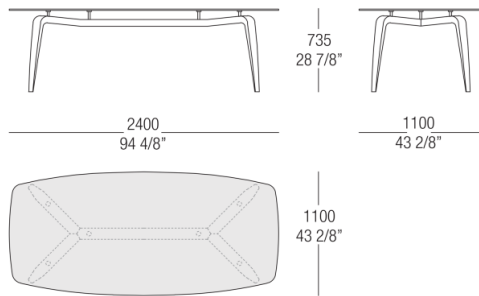

Glass top - Matt lacquer / glossy lacquer undertop

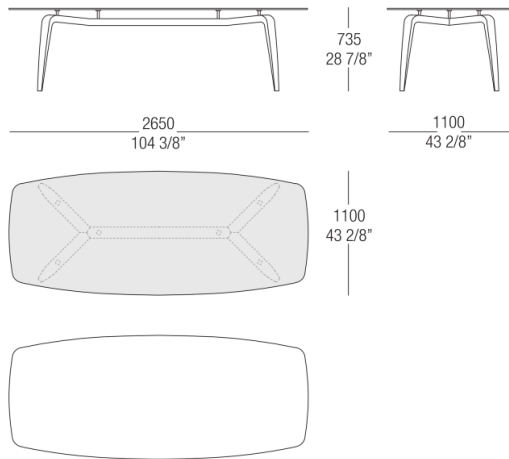

Wood top - Matt lacquer / glossy lacquer undertop

