

Harris

design by Giuseppe Viganò 2018



Structure: wood.

Structure upholstery: expanded polyurethane of varied densities (D35EM+D40P+HT45) covered with synthetic lining 230gr, coupled Dacron 380gr and coupled synthetic lining 6mm.

Seat upholstery: expanded polyurethane of varied densities (OS35S+D35EM+D50 mind foam) covered with synthetic lining 230gr and coupled Dacron 380gr.

Low back cushion upholstery: downproof cotton cover filled with 100% natural down.

Springing: elastic belts.

Seat height: 42 cm

Arm height: 85 cm

Feet: metal, finishes: black nickel or titanium or varnished micaceous brown or oxy grey, h.15 cm.

Struttura: legno.

Imbottitura fusto: poliuretano espanso a quote differenziate (D35EM+D40P+HT45) rivestito con Tomana 230 gr., Dacron accoppiato 380 gr. e accoppiato 6 mm.

Imbottitura seduta: poliuretano espanso a quote differenziate (OS35S+D35EM+D50 mind foam) rivestito con Tomana 230 gr. e Dacron accoppiato 380 gr.

Imbottitura cuscino poggiatesta: rivestimento in cotone antipiuma; riempitura in piuma naturale 100%.

Piano di molleggio: cinghie elastiche.

Altezza seduta: 42 cm

Altezza bracciolo: 85 cm

Piedi: metallo, finiture: black nickel o titanio oppure verniciato marrone micaceo o oxy grey, h.15 cm.

Sofa
Divano

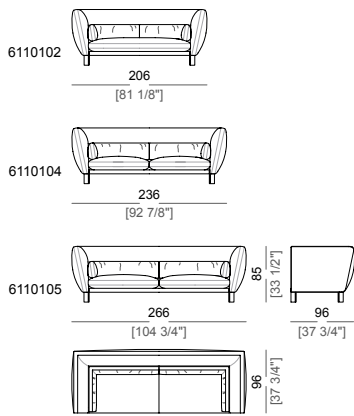

Sofa made by 2 units
Divano formato da 2 laterali

