

Armadio con ante scorrevoli CLASS / Wardrobe with CLASS sliding doors

NOVAMOBILI

CARATTERISTICHE TECNICHE TECHNICAL FEATURES

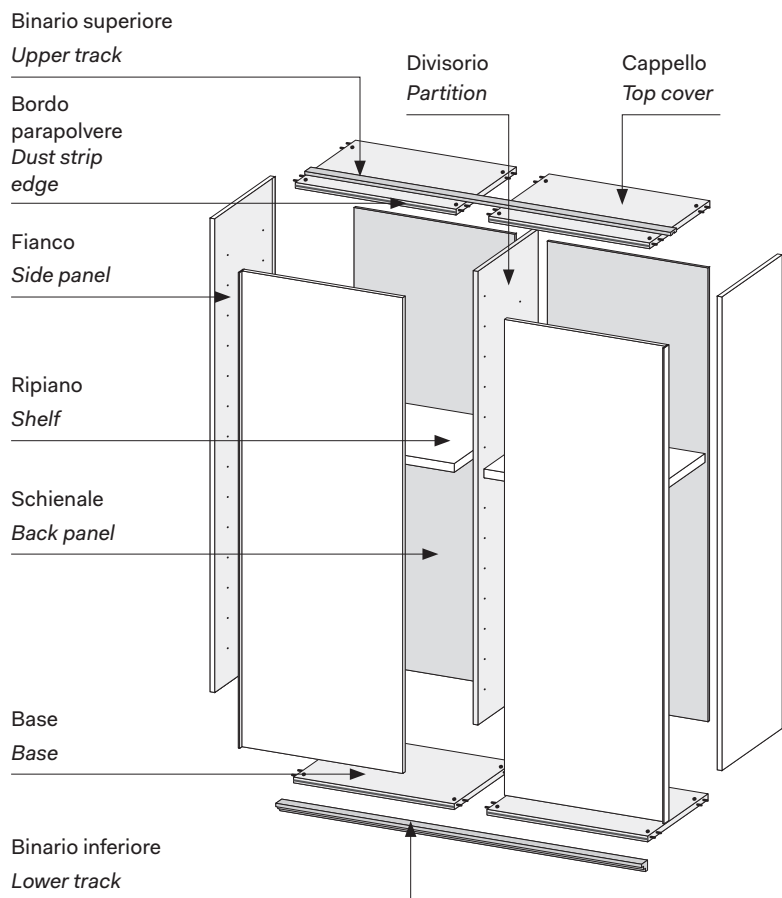

PARTICOLARE PIANTA PLAN DETAIL

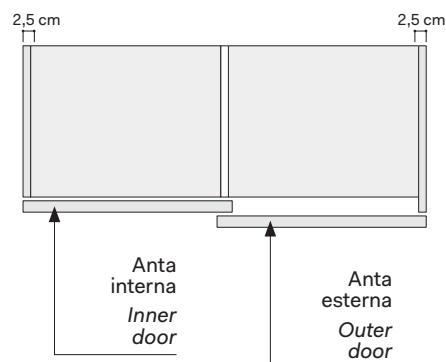

DOTAZIONE INTERNA STANDARD PER VANO STANDARD INTERIOR FITTINGS PER MODULE

- 1 ripiano interno mobile
- 2 tubi appendiabiti
- 1 internal shelf
- 2 hanging rails

ALTEZZE HEIGHTS

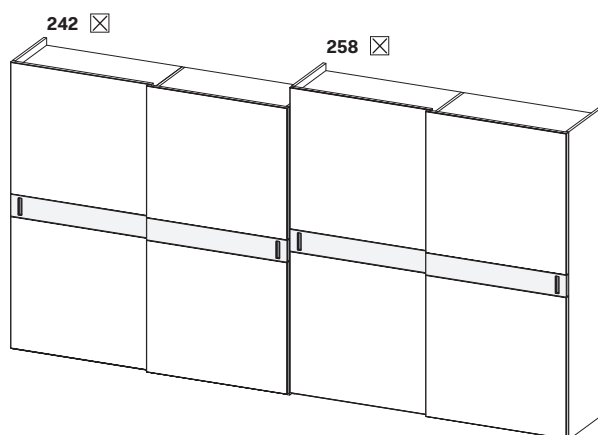

SEZIONE ANTA DOOR SECTION

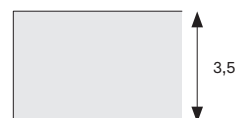

LARGHEZZE PROFONDITÀ WIDTHS DEPTH

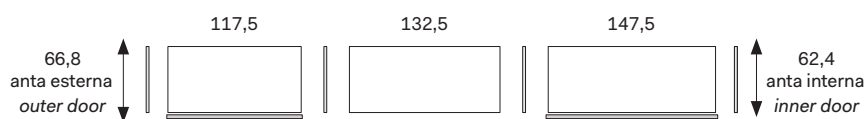

SCORREVOLE SLIDING



Le informazioni contenute nelle presenti schede tecniche sono indicative. Eventuali differenze con il listino in vigore non costituiscono motivo di contestazione.
The information given in this technical sheet are indicative. Any discrepancies with the price list currently in force cannot be cause for complaint.