

CALYPSO MARTINIQUE

TECHNICAL SHEET

UBICAZIONE : interni / LOCATION : indoor

CODICE IP / IP CODE : IP20

TIPOLOGIA / TYPOLOGY :

Lampada a sospensione / Pendant lamp

FINITURE e MATERIALI / FINISHES and MATERIALS :

Struttura in ottone spazzolato / Satin brass body

Diffusore in vetro trasparente / Transparent glass diffuser

PARALUME / SHADE :



BLACK



YELLOW



BUILDING



WHITE

CABLE

MATERIALE / MATERIAL :

Corda in seta intrecciata color verde muschio

Moss green braided silk cord

LUNGHEZZA CAVO / LENGTH OF THE CABLE :

2000 mm

LIGHT SOURCE

FONTE raccomandata / recommended SOURCE :

1 x E27 LED

POTENZA / POWER : 14 W

TEMPERATURA DI COLORE / COLOUR TEMPERATURE :

2700 K

CRI : >80

ALIMENTAZIONE / TENSION : 220 V

TECHNICAL DRAWINGS

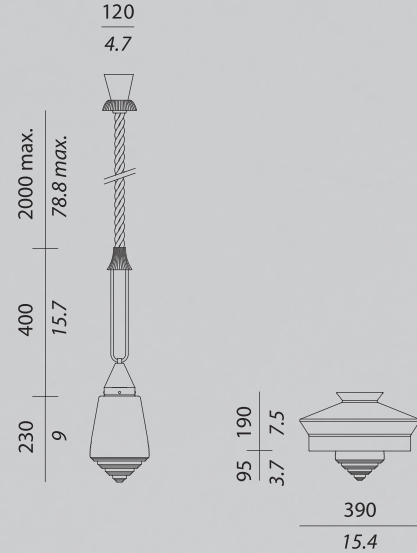

CON TARDI® CALYPSO MARTINIQUE



Questo dispositivo è compatibile con lampade di classi energetiche:

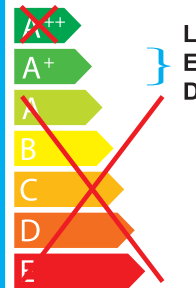

874/2012



CERTIFICATION

CE

BOX SIZES

Box 1:

WIDTH : 55 cm / 21.7 inc
DEPTH : 24 cm / 9.5 inc
HEIGHT : 30 cm / 11.8 inc
WEIGHT : 3,5 kg

Box 2:

WIDTH : 43 cm / 17 inc
DEPTH : 43 cm / 17 inc
HEIGHT : 26 cm / 10.3 inc
WEIGHT : 1,5 kg