

# CALYPSO OUTDOOR MARTINIQUE

## TECHNICAL SHEET

**UBICAZIONE** : esterni / **LOCATION** : wet location

**CODICE IP / IP CODE** : IP65

**TIPOLOGIA / TYPOLOGY** :

Lampada a sospensione / Pendant lamp

**FINITURE e MATERIALI / FINISHES and MATERIALS** :

Struttura in ottone spazzolato / Satin brass body

Diffusore in vetro trasparente / Transparent glass diffuser

**PARALUME / SHADE** :

Tessuti impermeabili / Waterproof fabrics

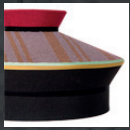

BLACK

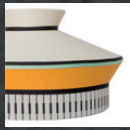

YELLOW

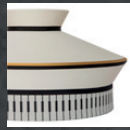

BUILDING



WHITE

## CABLE

**MATERIALE / MATERIAL** :

Corda in filato impermeabile intrecciato color verde muschio

Moss green waterproof braided cord

**LUNGHEZZA CAVO / LENGTH OF THE CABLE** :

2000 mm

## LIGHT SOURCE

**FONTE raccomandata / recommended SOURCE** :

1 x E27 LED

**POTENZA / POWER** : 8 W

**TEMPERATURA DI COLORE / COLOUR TEMPERATURE** :

3000 K

**CRI** : >80

**EMISSIONE / EMISSION** : 1 x 810 Lm

**ALIMENTAZIONE / TENSION** : 220 V

## TECHNICAL DRAWINGS

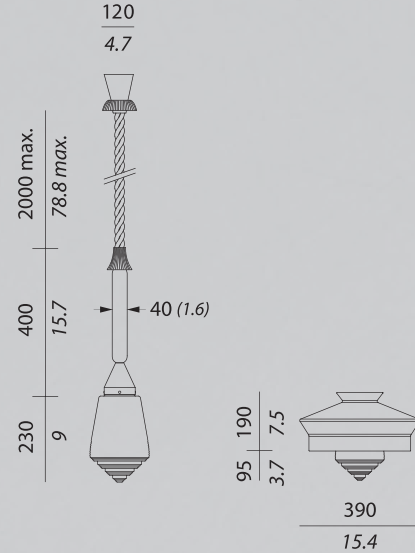

**BONTARDI®** CALYPSO OUTDOOR MARTINIQUE

 Questo dispositivo è compatibile con lampade di classi energetiche:

A++  
A+  
A  
B  
C  
D  
E

LED

Questa lampada è venduta con una lampadina di classe energetica: A++

874/2012 



## CERTIFICATION



## BOX SIZES

Box 1:

**WIDTH** : 55 cm / 21.7 inc  
**DEPTH** : 24 cm / 9.5 inc  
**HEIGHT** : 30 cm / 11.8 inc  
**WEIGHT** : 3,5 kg

Box 2:

**WIDTH** : 43 cm / 17 inc  
**DEPTH** : 43 cm / 17 inc  
**HEIGHT** : 26 cm / 10.3 inc  
**WEIGHT** : 1,5 kg