

	<p>Illuminazione/ lighting</p>
	<p>125</p>
	<p>ALAM125C</p>
	<p>Lampada a parete Wall-Mounted lights</p>



- Leggere le istruzioni prima di installare e utilizzare l'apparecchio.

- Conservare le istruzioni.  
- L'installazione deve essere effettuata da personale qualificato.

- L'installazione deve avvenire nel rispetto delle norme vigenti nel paese.

- Se il cavo di alimentazione è danneggiato, va sostituito dal costruttore, dal suo servizio assistenza, oppure da persona/azienda autorizzata.

- Prima di iniziare il montaggio assicurarsi di TOGLIERE TENSIONE dall'impianto elettrico.

- Conservare l'imballo fino ad accertamento del buon funzionamento dell'articolo.

- Rifiuto speciale elettrico - Smaltire negli appositi centri di raccolta



- Read the instructions before installing and using the device.

- Conserve the instructions.

- The installation has to be effected by trained personnel.

- The installation has to respect the valid standards .

- If the power cable is damaged, it has to be replaced by the supplier, by his customer service or by an authorized company /person.

- Before installing, please verify that the electric plant is not under tension.

- Conserve the package until you checked the articles functionality.

- Electric special waste dispose in the relevant waste collector



#### MANUTENZIONE

Per la normale pulizia si consiglia di utilizzare detergenti di uso comune.  
Si sconsiglia l'utilizzo di detergenti abrasivi, acidi e anticalcare.

DATI TECNICI  
Max 100W - E14 - 220V -  
IP 20 - -   
PER MERCATO USA  
100W - E11 - 110V

Prodotto conforme alle direttive vigenti.

Apparecchio installabile su superfici infiammabili.

#### NOTA

La ferramenta in dotazione permette il fissaggio su pareti in mattoni pieni o forati e in calcestruzzo. Per pareti in cartongesso è necessario rinforzare adeguatamente la zona interessata ed eventualmente adottare sistemi di fissaggio specifici.

#### MAINTENANCE

For normal cleaning use common detergents. Do not use either abrasive detergents or solvents, acids and anti limestone.

TECHNICAL DATA  
Max 100W - E14 - 220V -  
IP 20 - -   
FOR US MARKET  
100W - E11 - 110V

Manufactured according to running norms.

The lamp can be mounted on inflammable surfaces.

#### NOTE

The assembly material supplied allows the installation on solid and hollow brick walls and on concrete walls. For plasterboard walls it is necessary to reinforce adequately the area concerned and to adopt specific fixing systems if necessary.

#### Agape srl

via A. Pitentino, 6 46037 Governolo  
Roncoferraro (MN), Italy

T +39 0376 250311 / F +39 0376 250330

e-mail: [info@agapedesign.it](mailto:info@agapedesign.it)

[www.agapedesign.it](http://www.agapedesign.it)

ALAM125C		2/4
COD.	VERS.	
99271	20150525/2 - SV	

CONTENUTO DELLA CONFEZIONE  
PACKAGE CONTENTS

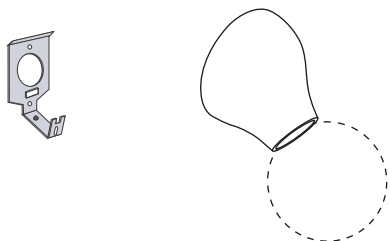

fissaggi / fixing



STRUMENTI  
TOOLS

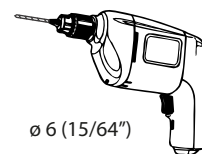
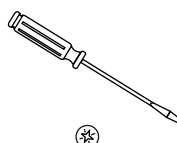

PREDISPOSIZIO  
NE



ACCESSORI INSTALLATI  
ACCESSORIES MOUNTED

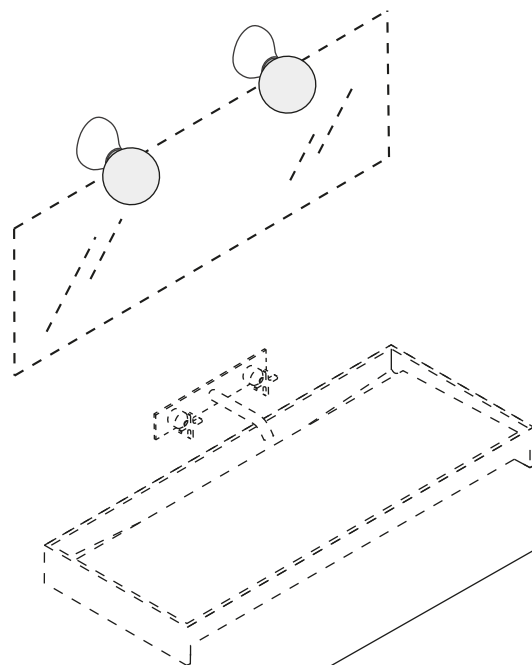

<p>1</p>	<p>La lampada "125/C" può essere fissata con il diffusore in vetro rivolto verso il basso, (1) lateralmente, (2) o verso l'alto (3). Lamp "125/C" can be fixed to the wall with the glass bowl turned downwards (1),sidwards (2) or upwards (3)</p>	<p>2</p>
<p>1                      2                      3</p>		<p>4</p>
<p>3</p>		
<p>5</p>		<p>6</p> <p>Collegare i cavi elettrici nel morsetto, tenere la massa all'esterno della scatola. Connect the wires into the terminal, keep the mass outside of the box.</p>

7

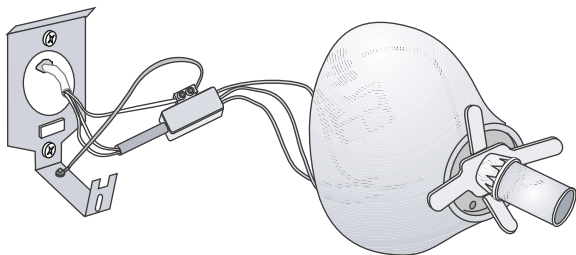

8

(A) Infilare la ceramica e bloccare con la vite (B) senza forzare.  
Thread the ceramic block with the screw (B) without forcing.

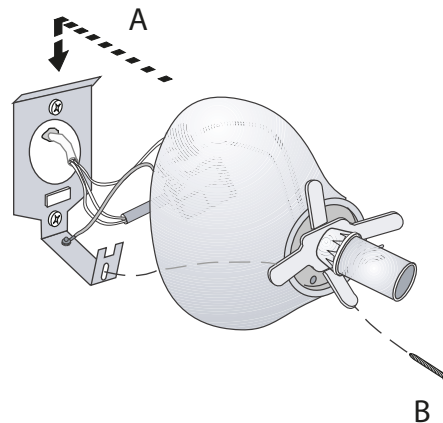

9

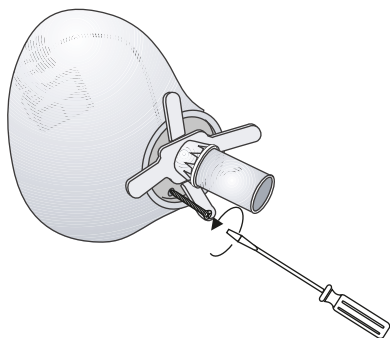

10

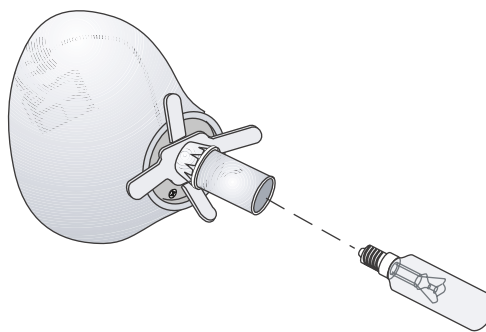

11

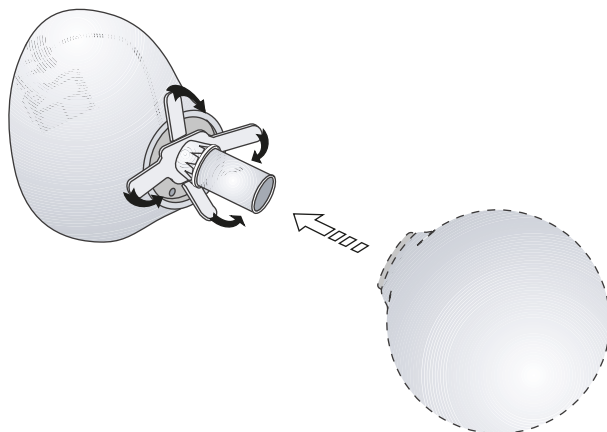

TIPOLOGIE DI DIFFUSORI / TYPES OF DIFFUSER

AVET322



AVET324

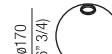

AVET325

