

catalogo vasi

**017**  
**antoniolupi**



# IGIGANTI

grandi vasi per esterno

*large vases for outdoor*

design Carlo Colombo



Nulla è più figlio dell'arte  
di un giardino.

*Nothing is more the child  
of art than a garden.*

(Sir Walter Scott)

**antoniolupi**



**Gargantua**

**Pantagruel**

**Gulliver**

**Polifemo**

**King Kong**

Praticamente indistruttibili, i nostri vasi realizzati con materiali di origine naturale quali ghiaia, sabbia e cemento tipo 4.25 e armati con fibre sintetiche ricavate da miscela polimerica per il rinforzo del calcestruzzo, possono caratterizzare con la loro presenza giardini, ingressi, viali, accogliendo date le dimensioni anche alberi e rampicanti. Il loro design moderno e raffinato, permette di inserirli in qualunque tipo di spazio, da quello di gusto classico a quello decisamente moderno.

La possibilità di verniciarli con vernici al quarzo, resistenti agli agenti atmosferici, consente anche di creare angoli colorati o di mimetizzarli con l'ambiente, ma anche di svolgere un ruolo importante per la salute delle piante: vasi di colore chiaro, essendo riflettenti, mantengono il terreno più fresco, mentre vasi di colore scuro, assorbendo i raggi solari, lo riscaldano. Per questo è bene informarsi dal vivaista su quali sono le temperature di benessere per la pianta che si decide di invasare.

I GIGANTI sono secondo noi i vasi che mancavano, quelli che portano all'esterno tutta la filosofia antioniolupi in fatto di design, qualità, artigianalità e funzionalità.

Per qualunque informazione, rivolgersi in Azienda.

*Virtually indestructible, our vases are made from natural materials such as gravel, sand and cement type 4.25 and equipped with synthetic fibers extracted from a polymer blend for the reinforcement of concrete. They can make a difference in gardens, entrances, driveways with trees and creepers given the sizes. Their modern and refined design allows you to insert them into any type of space, from classical to a more modern style.*

*The ability to paint them with Quartz based paint, weather resistant, allows you to create colorful corners or camouflage them with the environment. Play an important role in the health of your plants: light-colored vases are reflective and so maintain the ground cooler, while dark colored vases absorb sunlight and heat it. For this you should ask the nursery what the correct temperature of ground will establish well-being for the plant that you decide to plant.*

*I GIGANTI are, in our opinion, the vases that were missing, those that bring out the antioniolupi philosophy in terms of design, quality, craftsmanship and functionality.*

*For further information please contact the Company.*

perché

## IGIGANTI

Cercavamo dei grandi vasi in cemento per far più bella la nostra azienda ma incontentabili come siamo, non abbiamo trovato niente che ci soddisfacesse, così stavamo per rinunciare, quando ci siamo detti "perché non chiedere a Carlo, che ci conosce bene, se ha voglia di disegnare dei vasi per noi?". Così è nata questa collezione di vasi progettata da Carlo Colombo. Ci è sembrato poi assurdo che dei contenitori così belli fossero limitati al nostro "giardino" e abbiamo deciso di produrli. I vasi sono trattati internamente per essere idrorepellenti e possono essere verniciati del colore desiderato.

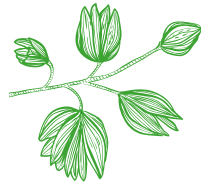

why

## IGIGANTI

*We were looking for large concrete vases to make our company more beautiful but insatiable as we are, we didn't find anything that would satisfy us, so we were about to give up when we said "why not ask Carlo, who knows us well, if he wants to design some vases for us?" This is how the collection of vases designed by Carlo Colombo came about. Then it seemed absurd that such beautiful containers were limited to our "garden" so we decided to produce them. The vases are internally treated to be waterproof and can be painted in the desired color.*

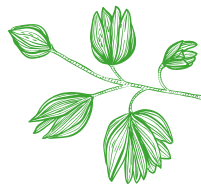

# Gargantua

**Gargantua** è il figlio del re di Utopia, il gigante Grandgousier. Partorito da un orecchio della madre Gargamelle, riceve un'educazione medievale che nel libro viene ridicolizzata. Il saggio Ponocrate gli insegnerà un nuovo metodo di studio consistente nel considerare i libri come maestri di vita. Quando scoppierà una guerra per una lite tra mercanti di focacce, tra il regno di Utopia e quello del re Picrochole, Gargantua, grazie all'aiuto di frate Jean des Entommeurs (Fracassatutto), riuscirà a vincere la guerra, dimostrandosi poi generoso con i vinti e ricompensando il frate con la costruzione di un monastero la cui regola sarà "Fai ciò che vuoi".

**Gargantua** is the son of the King of Utopia, the Grandgousier giant. Born from the ear of his mother, Gargamelle receives medieval education which in the book is ridiculed. The wise Ponocrates will teach him a new method of study consisting in considering books as teachers of life. When the war breaks out due to a quarrel between bread merchants, between the kingdom of Utopia and that of king Picrochole, Gargantua, with the help of the friar Jean des Entommeurs, wins the war and is generous to those defeated and rewards the friar with the construction of a monastery whose rule is "Do what thou wilt."

Gargantua e Pantagruel (*La vie de Gargantua et de Pantagruel*) è una serie di cinque romanzi scritti da François Rabelais nella prima metà del Cinquecento.

*Gargantua and Pantagruel (La vie de Gargantua et de Pantagruel)* is a series of five novels written by François Rabelais in the first half of the sixteenth century.



**Gargantua01**

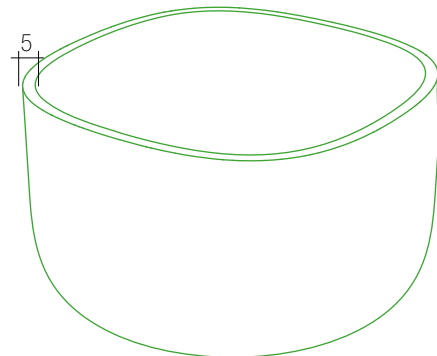
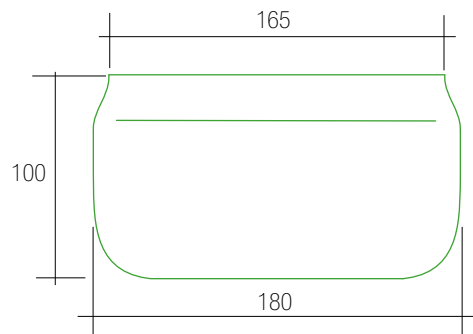







**Gargantua02**

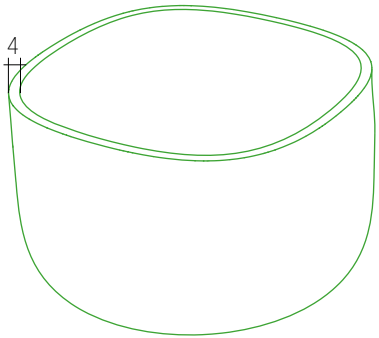
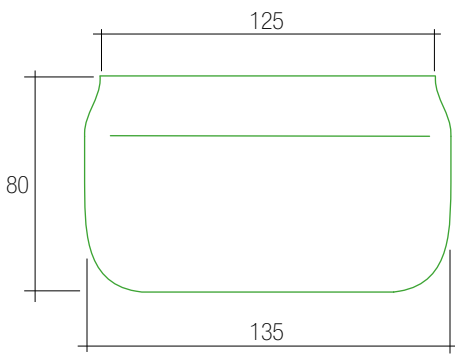

**Gargantua04**

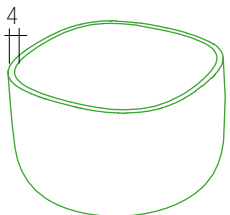
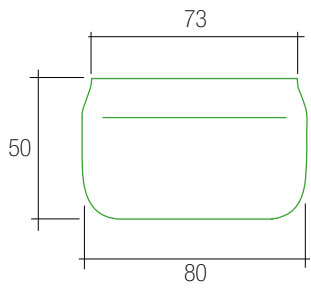





**Gargantua03**

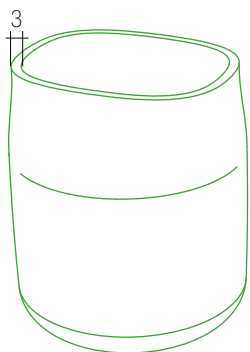
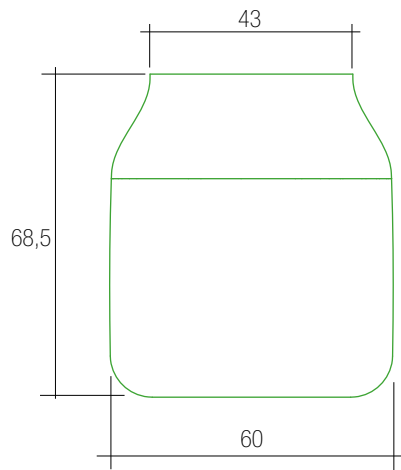

# Pantagruel

**Pantagruel**, figlio del gigante Gargantua e di Badebec che muore nel partorirlo, riceve un'educazione umanista e si distingue fin da piccolo per una forza ed un appetito spaventosi. A Parigi è amico di un chierico spiantato, Panurge, con il quale vive numerose avventure. Quando i Dipsodi invadono Utopia, Pantagruel, grazie alla sua forza, li respinge, non senza aver riparato con la lingua dalla pioggia, un intero battaglione. Mastro Alcofribas Nasier (il narratore, anagramma di François Rabelais) approfitta della situazione per entrarli in bocca dove trova boschi e campi curati dalle popolazioni che vi vivono.

**Pantagruel**, son of the giant Gargantua and Badebec who dies when gives birth, receives a humanist education and stands out as a child for strength and a fearsome appetite. In Paris he is friends with a penniless clergyman, Panurge, with whom he lives many adventures. When Dipsodes invades Utopia, Pantagruel, thanks to his strength, rejects them after having sheltered an entire battalion with his tongue. Master Alcofribas Nasier (the narrator, an anagram of François Rabelais) takes advantage of the situation to get into his mouth where he finds woods and fields tended to by the people who live there.

Gargantua e Pantagruel (*La vie de Gargantua et de Pantagruel*) è una serie di cinque romanzi scritti da François Rabelais nella prima metà del Cinquecento.

*Gargantua and Pantagruel (La vie de Gargantua et de Pantagruel)* is a series of five novels written by François Rabelais in the first half of the sixteenth century.

Pantagruel01

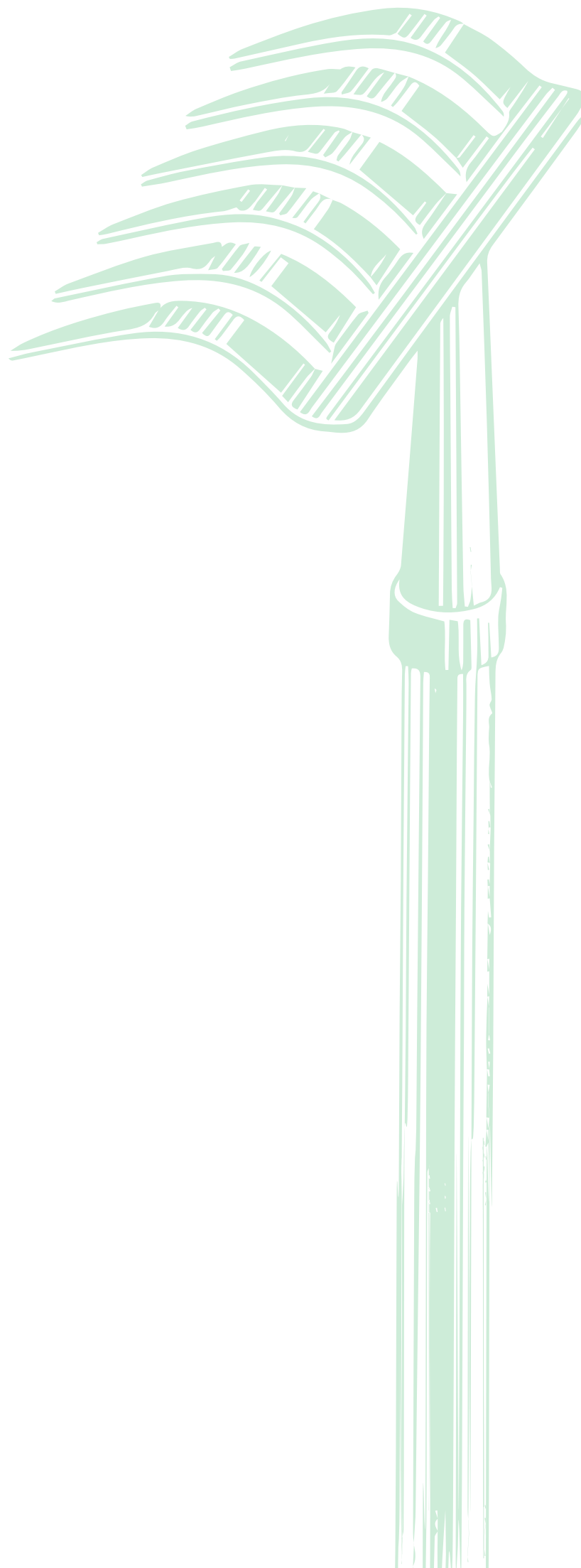
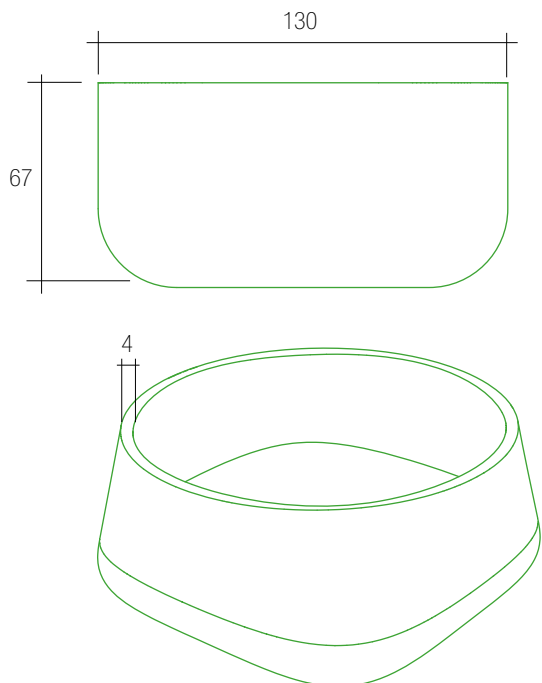



antoniolupi raccomanda di utilizzare vernici al quarzo.  
*antoniolupi recommends using paints with quartz.*





# Polifemo

**Polifemo.** Omero ne parla nell'Odissea, quando Ulisse sbarcato in Sicilia, nella Terra dei Ciclopi, viene catturato insieme ai suoi compagni appunto da Polifemo, figlio di Poseidone. Intrappolato nella sua caverna che era chiusa da un enorme masso, Ulisse, offrì del vino dolce e forte al gigante che aveva già divorato sei dei suoi uomini. Polifemo gradì il vino e promise a Ulisse un dono, a patto di conoscere il suo nome. Ulisse rispose astutamente di chiamarsi Nessuno e il gigante allora promise che avrebbe mangiato per ultimo appunto Nessuno. Dopo di che si addormentò profondamente, dando modo a Ulisse e ai suoi compagni di piantargli un palo di olivo arroventato, nell'unico occhio centrale. Alle urla disperate del Ciclope, gli altri giganti gli chiesero cosa stesse accadendo e Polifemo rispose che Nessuno stava tentando di ucciderlo, così se ne andarono pensandolo ubriaco. Al mattino, quando Polifemo ormai cieco, fece uscire il suo gregge dalla grotta, i greci riuscirono a fuggire aggrappandosi ognuno al vello del ventre di una pecora che invano il Ciclope tastava sulla schiena.

L'Odissea è uno dei due grandi poemi epici greci attribuiti all'opera del poeta Omero. Narra delle vicende riguardanti l'eroe Odisseo (o Ulisse, con il nome latino), dopo la fine della Guerra di Troia, narrata nell'Iliade.

*The Odyssey is one of the two great Greek epic poems attributed to the work of the poet Homer. It tells the story about the hero Odysseus (or Ulysses, in Latin), after the end of the Trojan War, as told in the Iliad.*





Polifemo01

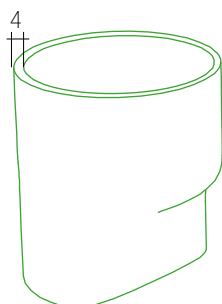
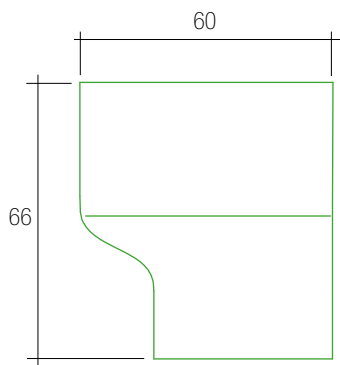

Polifemo02

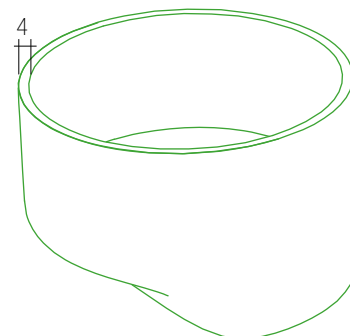
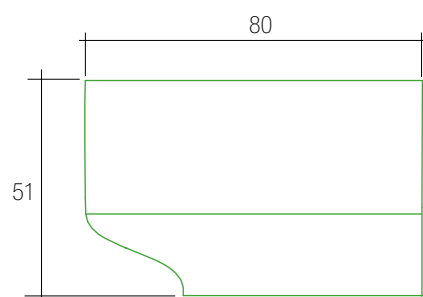

**POLIFEMO (POLYPHEMUS).** Homer speaks in *Odyssey*, when Odysseus landed in Sicily, land of the Cyclops, was captured along with his companions precisely by Polyphemus, son of Poseidon. Trapped in his cave which was closed by a huge boulder, Ulysses, offered a sweet and strong wine to the giant who had already devoured six of his men. Polyphemus was grateful for the wine and promised Ulysses a gift, provided he told his name. Ulysses replied cunningly, my name is Nobody and the giant then promised that he would eat lastly Nobody. After that he fell deeply asleep, giving way to Ulysses and his comrades to plant an olive stick in his one central eye. The desperate cries of the Cyclops made the other giants ask him what was going on and Polyphemus replied that Nobody was trying to kill him, so they left thinking he was drunk. In the morning, the now blind Polyphemus, brought out his flock from the cave, the Greeks escaped by clinging to the fleece of a sheep who vainly probed the Cyclops on his back.





# Gulliver

**Gulliver**, per mancanza di denaro, decide di imbarcarsi su una nave come chirurgo di bordo. Salpato da Bristol il 4 maggio 1699, naufraga su una terra sconosciuta per un terribile temporale dopo sette mesi di navigazione. Al risveglio si trova legato da uomini alti circa 15 centimetri, abitanti delle isole di Lilliput e Blefuscu (la Francia e l'Inghilterra), divise fino al fratricidio, da un'annosa controversia sul modo più corretto di rompere le uova, se dalla parte più grossa o da quella più piccola (allegoria delle dispute tra cattolici e anglicani). Dopo aver dimostrato di essere un uomo venuto in pace e giurato fedeltà all'Imperatore, viene accolto nel grande palazzo e gli vengono offerti alloggio e cibo. Le sue osservazioni sulla corte dei Lilliput (la corte di Giorgio I) ridicolizzano le lotte tra le varie fazioni, rappresentate dalla rivalità tra "tacchi alti" e "tacchi bassi" (i partiti Whigs e Tories) e i metodi con cui viene conquistato il potere.

**Gulliver**, due to the lack of money, decides to embark on a ship as an on board surgeon. Set sail from Bristol May 4, 1699, is shipwrecked on unknown land because of a terrible storm after seven months at sea. Upon awakening he finds himself tied up by men approximately 15 centimeters tall, inhabitants of the Lilliput and Blefuscu islands (France and England), divided up due to fratricide, from what was the correct way to break eggs, if from the larger or smaller side (allegory of disputes between Catholics and Anglicans). After proving to be a man he made peace and pledged allegiance to the Emperor, is welcomed in the great palace and offered lodging and food. His remarks in the court of Lilliput (the court of George I) ridicules the struggles between various factions, represented by the rivalry between "high heels" and "low heels" (the Whigs and Tories parties) and the methods with which power is seized.

I viaggi di Gulliver è il capolavoro dello scrittore irlandese Jonathan Swift, pubblicato inizialmente anonimo nel 1726.

*Travels into Several Remote Nations of the World, is the masterpiece of the Irish writer Jonathan Swift, initially published anonymously in 1726.*



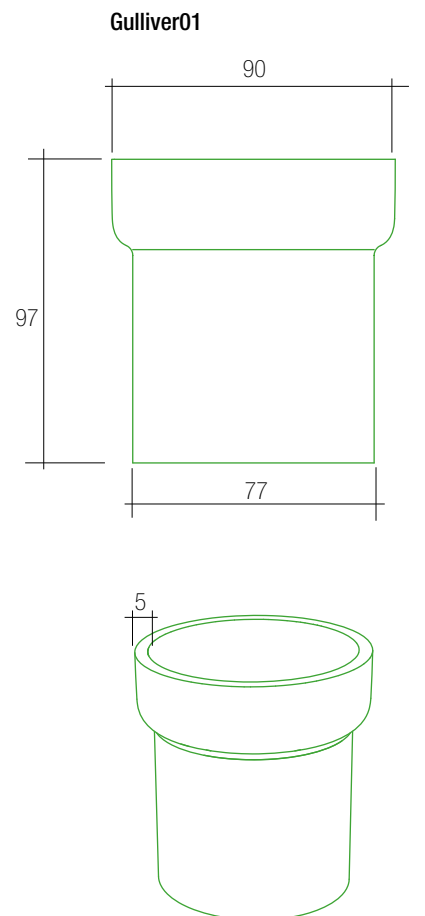





**Gulliver02**

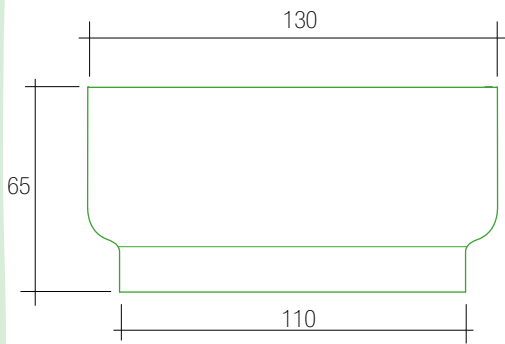

**Gulliver03**

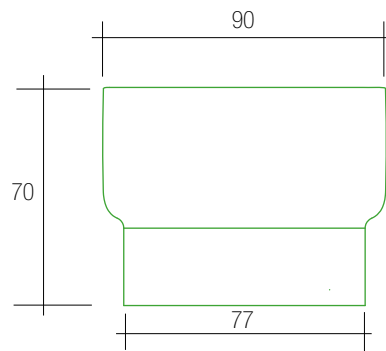

**Gulliver04**

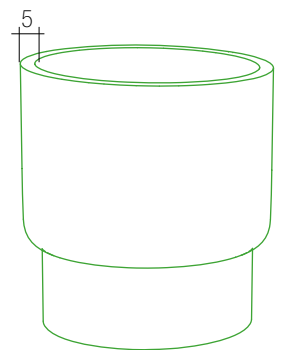
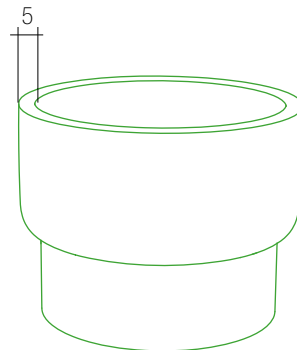
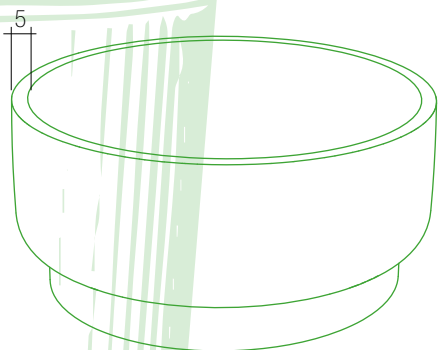
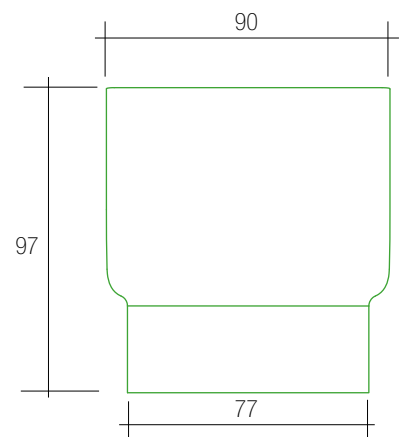









# KingKong

**King Kong.** Protagonista di numerosi film, è un gigante cinematografico immaginario, dall'aspetto di un gorilla. Originario della leggendaria isola conosciuta come Isola del Teschio. King Kong è l'ultimo rimasto di una gigantesca specie di primate nota come Megaprimatus Kong. Nel primo film il suo nome è Kong, il prenome King (re, sovrano) venne poi aggiunto in suo onore. È stato anche definito "l'ottava meraviglia del mondo", tanto che uno dei titoli che furono proposti per il film uscito nel 1933, era "The Eighth Wonder".

**King Kong.** Starred in several films, is an imaginary film giant, which looks like a gorilla. Originally from the legendary island known as Skull Island. King Kong is the last one left of a giant species of primates known as Megaprimatus Kong. In the first film his name is Kong, the forename King (King, ruler) was then added in his honor. He's also been called "the eighth wonder of the world", so much so that one of the titles proposed for the film released in 1933, was "The Eighth Wonder".

KingKong01

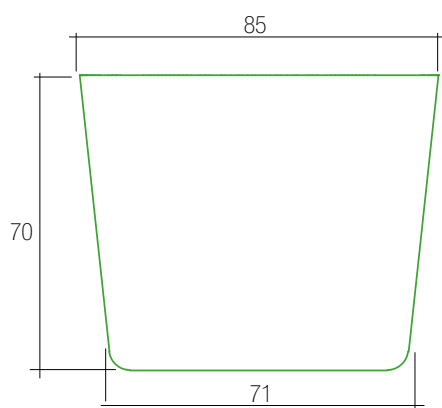

KingKong02

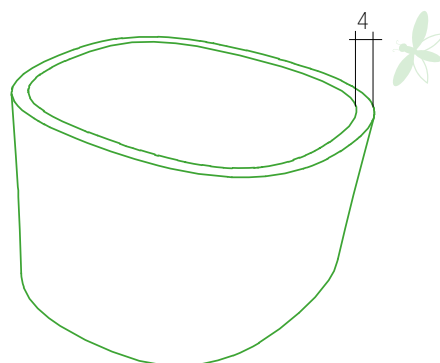
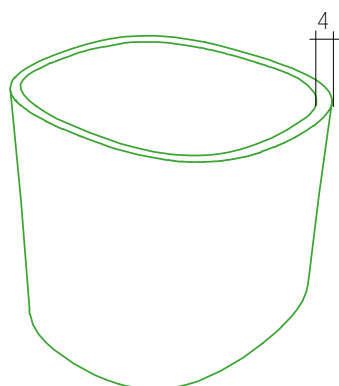
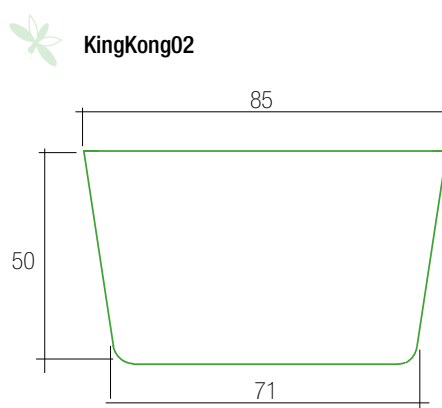







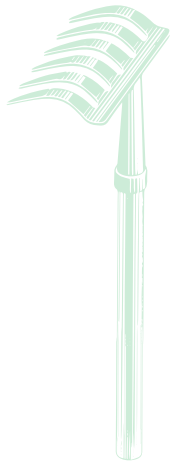
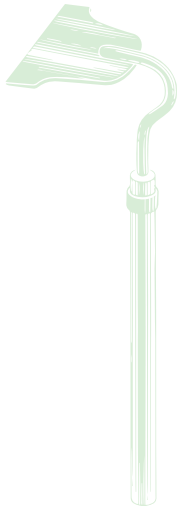



Nel giardinaggio c'è qualcosa di simile alla presunzione e al piacere della creazione: si può plasmare un pezzetto di terra come si vuole, per l'estate ci si può procurare i frutti, i colori e i profumi che si preferiscono. Si può trasformare una piccola aiola, un paio di metri quadrati di nuda terra, in un mare di colori, in una delizia per gli occhi, in un angolo di paradiso.

*In the garden there is something similar to the presumption and the pleasure of creation: you can shape a piece of land as you want, in the summer you can obtain fruit, colors and the scents you prefer from it. You can turn a small flowerbed or a few square meters of bare ground into a sea of color, a delight for the eyes, a corner of paradise.*

Hermann Hesse

I nostri vasi sono trattati in modo da essere impermeabilizzati sia all'interno che all'esterno per impedire al cemento di assorbire l'acqua. Con questo trattamento e una volta riempiti dello strato drenante con l'argilla e successivamente con la terra, resistono benissimo alle basse temperature. Unico rischio è se il vaso viene lasciato internamente vuoto con il foro intasato, in questo caso l'eventuale deposito di acqua, trasformandosi in ghiaccio, potrebbe provocare schianti e rotture. Nell'impasto è comunque previsto un prodotto antigelo e fluidificante che ne aumenta le prestazioni sia alle basse che alle alte temperature. I manufatti non sono attaccabili da muffe.

*Our vases are treated to be waterproof inside and out to prevent that the cement absorbs water. With this treatment and once filled with a layer of clay and dirt they will resist very well to low temperatures. The only risk is if the vase is left empty and the hole is clogged where any deposit of water that transforms into ice can cause cracks and breakage. Within the mixture of cement there is antifreeze and fluidization products that increase the characteristics in very low and high temperatures. Mold cannot stick to the various articles.*

N.B

I nostri vasi in cemento sono realizzati con tecniche artigianali, ogni vaso è un pezzo unico, eventuali imperfezioni, come variazioni di tonalità e spessore, non possono essere considerati motivi di contestazione.

P.S.

*Our concrete vases are made with traditional techniques, each vase is a single piece, any imperfections, such as shade variations and thickness, cannot be considered reasons of dispute.*



Si ringrazia vivamente la Giorgio Tesi Group di Pistoia che ci ha fornito le piante per il nostro giardino.

*We strongly thank Giorgio Tesi Group of Pistoia  
Who provided the plants for our garden  
[www.giorgiotesigroup.it](http://www.giorgiotesigroup.it)*







- IT** - I vasi della collezione IGIGANTI sono realizzati con materiali di origine naturale quali ghiaia, sabbia e cemento tipo 4.25 e armati con fibre sintetiche ricavate da miscela polimerica per il rinforzo del calcestruzzo, che li rende estremamente resistenti.  
La possibilità di verniciarli con vernici al quarzo, resistenti agli agenti atmosferici consente, sia di creare angoli colorati, che di svolgere un ruolo importante per la salute delle piante: vasi di colore chiaro, essendo riflettenti, mantengono il terreno più fresco, mentre vasi di colore scuro, assorbendo i raggi solari, lo riscaldano. Per questo è bene informarsi dal vivaista su quali sono le temperature di benessere per la pianta che si decide di invasare.  
Essendo realizzati con tecniche artigianali, ogni vaso è un pezzo unico; eventuali imperfezioni, come variazioni di tonalità e spessore, non possono essere considerati motivi di contestazione.  
La resa è franco fabbrica.
- EN** - Vases of the collection IGIGANTI are made with natural materials such as gravel, sand and cement type 4.25 and equipped with synthetic fibers extracted from a polymer blend for the reinforcement of concrete, making them indestructible.  
The ability to paint them with Quartz based paint, weather resistant, allows you to create colorful corners as well as play an important role in the health of your plants: light-colored vases are reflective and so maintain the ground cooler, while dark colored vases absorb sunlight and heat it. For this you should ask the nursery what the correct temperature of ground will establish well-being for the plant that you decide to plant.  
Made with traditional techniques, each vase is unique; eventual imperfections such as color shade differences or thicknesses of the material cannot be considered reasons for disputes.  
Shipment is Ex-Works.
- DE** - Die Vasen der Kollektion IGIGANTI werden aus Stoffen natürlichen Ursprungs wie Kies, Sand und Beton Typ 4,25 hergestellt und mit synthetischen Spinnfasern aus einer Polymermischung zur Betonverstärkung ausgestattet. Die Vasen, die mit wetterfesten Quarzlacken lackiert werden können, kreieren bunte Ecken und spielen auch eine wichtige Rolle für die Pflanzengesundheit: Hellfarbige Vasen reflektieren das Licht und daher bleibt die Bodentemperatur kühl; dunkelfarbige Vasen absorbieren dagegen die Sonnenstrahlen und wärmen den Boden. Es ist deswegen empfehlenswert, sich beim Landschaftsgärtner nach den adäquaten Temperaturen der gewünschten Pflanze zu erkundigen. Die Vasen sind mit Handwerkstechniken realisiert und daher ist jede Vase ein Einzelstück – mögliche Fehlerhaftigkeiten wie Farbton- oder Stärkeänderungen können nicht Anlass für Reklamation in irgendeiner Form geben.  
Die Lieferung ist ab Werk.
- FR** - Les vases de la collection IGIGANTI sont réalisés avec des matériaux d'origines naturelles comme le gravier, le sable et le ciment 4.25 et armé avec des fibres synthétiques obtenues d'un mélange polymérique pour renforcer le béton ce qui le rend extrêmement résistant.  
La possibilité de les peindre avec de la peinture au quartz, résistant aux agents atmosphériques, permet de créer des coins de couleurs et joue un rôle important pour la santé des plantes : les vases de couleurs claires réfléchissent la lumière et maintiennent le sol plus frais tandis que les vases de couleurs foncées, absorbent les rayons du soleil et le réchauffent. Il faut donc s'informer au près du pépiniériste pour connaître la température idéale au bien-être de la plante que l'on décide de mettre en vase.  
Chaque vase réalisé artisanalement est une pièce unique; d'éventuelles imperfections comme différences de tonalités et d'épaisseurs ne peuvent donner lieu à aucune réclamation.  
Prix franco usine.
- ES** - La macetas de la colección IGIGANTI están fabricados con materiales de origen natural como grava, arena y cemento tipo 4.25 enriquecidos con fibras sintéticas de mezcla polimérica para reforzar el hormigón. Las macetas se pueden lacar con pinturas al cuarzo resistentes a la intemperie, por tanto crean esquinas coloreadas y desempeñan también un papel importante para la salud de las plantas: las macetas de colores claros reflejan la luz y por tanto mantienen una temperatura baja del suelo, mientras que los colores oscuros absorben los rayos del sol y calentan el suelo. Por esta razón es aconsejable informarse con el vivero sobre las temperaturas adecuadas de la planta que se desea envasar. Las macetas se fabrican con técnicas artesanales, por tanto cada maceta es una pieza única. Posibles imperfecciones, como variación de tonalidad y grosor, no pueden suponer motivo de reclamación.  
La expedición es franco fábrica.
- RU** - Вазы коллекции IGIGANTI произведены из натуральных материалов, таких как гравий, песок и цемент типа 4.25, а также армированы с помощью синтетического волокна, изготовленного из полимерной смеси для армирования бетона, что делает их крайне устойчивыми. Возможно красить кварцевыми красками, стойкими к атмосферным воздействиям, тем самым создавая разноцветные уголки, которые играют важную роль в здоровье растений: вазы в светлых тонах, сохраняют более свежую почву, в то время, как вазы в темных тонах, поглощают солнечный свет и тепло. Перед выбором цвета для вазы, просьба обратиться к садовнику для получения информации о наилучшей температуре для Вашего растения.  
Они произведены ремесленным способом. Каждая ваза уникальна; вариации оттенков и толщины не являются недостатками и не могут рассматриваться как рекламации.  
Отгрузка Ex Works с завода.

## GARGANTUA

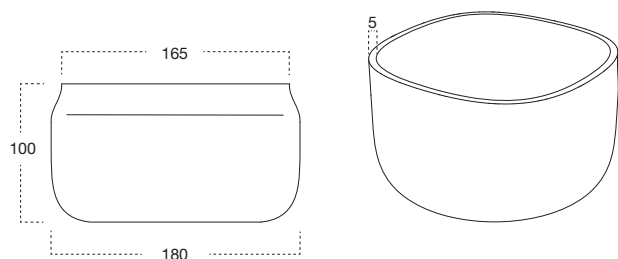

**IT - Peso lordo: 1743 Kg ca. Peso netto: 1660 Kg ca.**  
**EN - Gross weight: 1743 Kg approx. Net weight: 1660 Kg approx.**  
**DE - Bruttogewicht: 1743 Kg ca. Nettogewicht: 1660 Kg ca.**  
**FR - Poids brut: 1743 Kg environ. Poids net: 1660 Kg environ.**  
**ES - Peso bruto: 1743 Kg aprox. Peso neto: 1660 Kg aprox.**  
**RU - Вес брутто: ≈ 1743 кг. Вес нетто: ≈ 1660 кг.**

## ART.

GARGANTUA01

3.033

## GARGANTUA

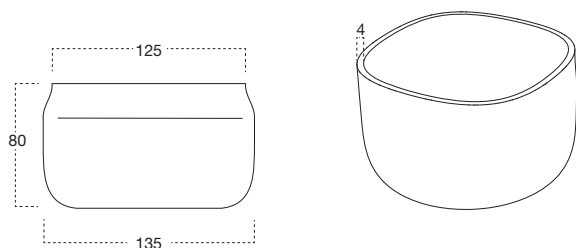

**IT - Peso lordo: 1056 Kg ca. Peso netto: 1005 Kg ca.**  
**EN - Gross weight: 1056 Kg approx. Net weight: 1005 Kg approx.**  
**DE - Bruttogewicht: 1056 Kg ca. Nettogewicht: 1005 Kg ca.**  
**FR - Poids brut: 1056 Kg environ. Poids net: 1005 Kg environ.**  
**ES - Peso bruto: 1056 Kg aprox. Peso neto: 1005 Kg aprox.**  
**RU - Вес брутто: ≈ 1056 кг. Вес нетто: ≈ 1005 кг.**

## ART.

GARGANTUA02

1.829

## GARGANTUA

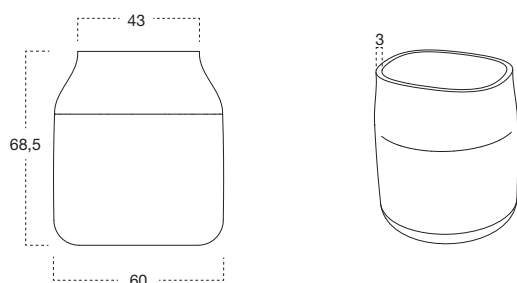

**IT - Peso lordo: 349 Kg ca. Peso netto: 330 Kg ca.**  
**EN - Gross weight: 349 Kg approx. Net weight: 330 Kg approx.**  
**DE - Bruttogewicht: 349 Kg ca. Nettogewicht: 330 Kg ca.**  
**FR - Poids brut: 349 Kg environ. Poids net: 330 Kg environ.**  
**ES - Peso bruto: 349 Kg aprox. Peso neto: 330 Kg aprox.**  
**RU - Вес брутто: ≈ 349 кг. Вес нетто: ≈ 330 кг.**

## ART.

GARGANTUA03

950

## GARGANTUA

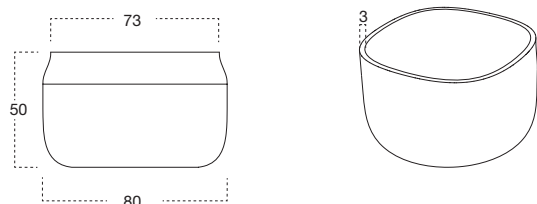

**IT - Peso lordo: 428 Kg ca. Peso netto: 405 Kg ca.**  
**EN - Gross weight: 428 Kg approx. Net weight: 405 Kg approx.**  
**DE - Bruttogewicht: 428 Kg ca. Nettogewicht: 405 Kg ca.**  
**FR - Poids brut: 428 Kg environ. Poids net: 405 Kg environ.**  
**ES - Peso bruto: 428 Kg aprox. Peso neto: 405 Kg aprox.**  
**RU - Вес брутто: ≈ 428 кг. Вес нетто: ≈ 405 кг.**

## ART.

GARGANTUA04

1.035

## POLIFEMO

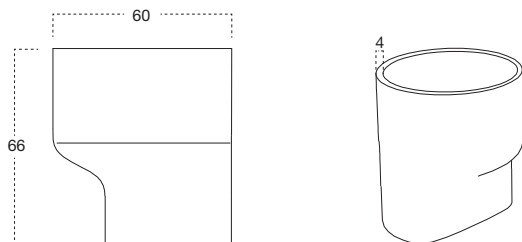

IT - **Peso lordo: 258 Kg ca. Peso netto: 240 Kg ca.**

EN - Gross weight: 258 Kg approx. Net weight: 240 Kg approx.

DE - Bruttogewicht: 258 Kg ca. Nettogewicht: 240 Kg ca.

FR - Poids brut: 258 Kg environ. Poids net: 240 Kg environ.

ES - Peso bruto: 258 Kg aprox. Peso neto: 240 Kg aprox.

RU - Вес брутто: ≈ 258 кг. Вес нетто: ≈ 240 кг.

ART.

POLIFEMO01

976

## POLIFEMO

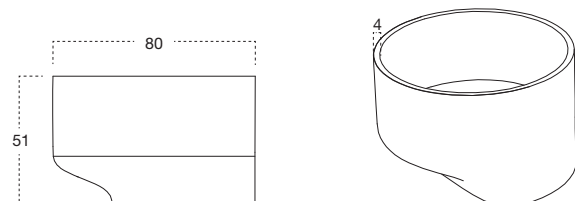

IT - **Peso lordo: 333 Kg ca. Peso netto: 310 Kg ca.**

EN - Gross weight: 333 Kg approx. Net weight: 310 Kg approx.

DE - Bruttogewicht: 333 Kg ca. Nettogewicht: 310 Kg ca.

FR - Poids brut: 333 Kg environ. Poids net: 310 Kg environ.

ES - Peso bruto: 333 Kg aprox. Peso neto: 310 Kg aprox.

RU - Вес брутто: ≈ 333 кг. Вес нетто: ≈ 310 кг.

ART.

POLIFEMO02

1.008

## GULLIVER

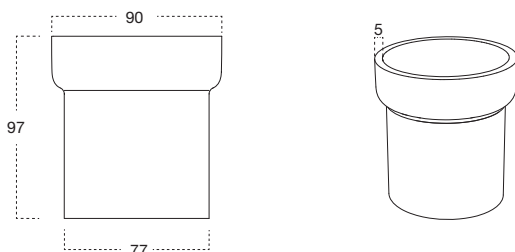

IT - **Peso lordo: 442 Kg ca. Peso netto: 410 Kg ca.**

EN - Gross weight: 442 Kg approx. Net weight: 410 Kg approx.

DE - Bruttogewicht: 442 Kg ca. Nettogewicht: 410 Kg ca.

FR - Poids brut: 442 Kg environ. Poids net: 410 Kg environ.

ES - Peso bruto: 442 Kg aprox. Peso neto: 410 Kg aprox.

RU - Вес брутто: ≈ 442 кг. Вес нетто: ≈ 410 кг.

ART.

GULLIVER01

1.216

## GULLIVER

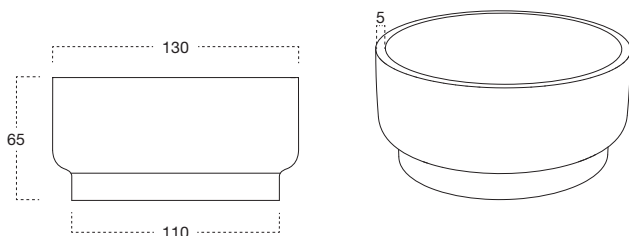

IT - **Peso lordo: 540 Kg ca. Peso netto: 498 Kg ca.**

EN - Gross weight: 540 Kg approx. Net weight: 498 Kg approx.

DE - Bruttogewicht: 540 Kg ca. Nettogewicht: 498 Kg ca.

FR - Poids brut: 540 Kg environ. Poids net: 498 Kg environ.

ES - Peso bruto: 540 Kg aprox. Peso neto: 498 Kg aprox.

RU - Вес брутто: ≈ 540 кг. Вес нетто: ≈ 498 кг.

ART.

GULLIVER02

1.508

## GULLIVER

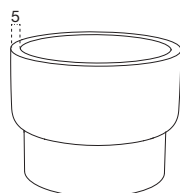
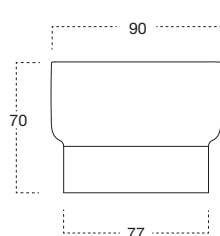

IT - **Peso lordo: 347 Kg ca. Peso netto: 320 Kg ca.**

EN - Gross weight: 347 Kg approx. Net weight: 320 Kg approx.

DE - Bruttogewicht: 347 Kg ca. Nettogewicht: 320 Kg ca.

FR - Poids brut: 347 Kg environ. Poids net: 320 Kg environ.

ES - Peso bruto: 347 Kg aprox. Peso neto: 320 Kg aprox.

RU - Вес брутто: ≈ 347 кг. Вес нетто: ≈ 320 кг.

ART.

GULLIVER03

1.113

## GULLIVER

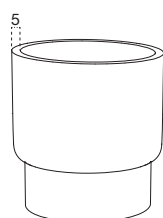
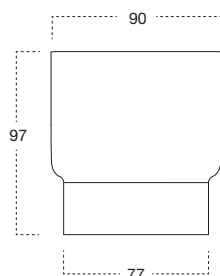

IT - **Peso lordo: 452 Kg ca. Peso netto: 420 Kg ca.**

EN - Gross weight: 452 Kg approx. Net weight: 420 Kg approx.

DE - Bruttogewicht: 452 Kg ca. Nettogewicht: 420 Kg ca.

FR - Poids brut: 452 Kg environ. Poids net: 420 Kg environ.

ES - Peso bruto: 452 Kg aprox. Peso neto: 420 Kg aprox.

RU - Вес брутто: ≈ 452 кг. Вес нетто: ≈ 420 кг.

ART.

GULLIVER04

1.216

## KINGKONG

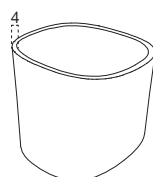
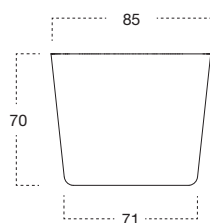

IT - **Peso lordo: 497 Kg ca. Peso netto: 470 Kg ca.**

EN - Gross weight: 497 Kg approx. Net weight: 470 Kg approx.

DE - Bruttogewicht: 497 Kg ca. Nettogewicht: 470 Kg ca.

FR - Poids brut: 497 Kg environ. Poids net: 470 Kg environ.

ES - Peso bruto: 497 Kg aprox. Peso neto: 470 Kg aprox.

RU - Вес брутто: ≈ 497 кг. Вес нетто: ≈ 470 кг.

ART.

KINGKONG01

1.112

## KINGKONG

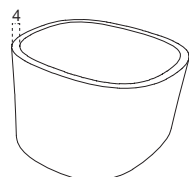
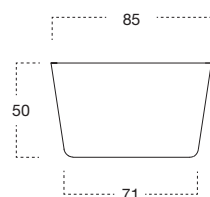

IT - **Peso lordo: 358 Kg ca. Peso netto: 336 Kg ca.**

EN - Gross weight: 358 Kg approx. Net weight: 336 Kg approx.

DE - Bruttogewicht: 358 Kg ca. Nettogewicht: 336 Kg ca.

FR - Poids brut: 358 Kg environ. Poids net: 336 Kg environ.

ES - Peso bruto: 358 Kg aprox. Peso neto: 336 Kg aprox.

RU - Вес брутто: ≈ 358 кг. Вес нетто: ≈ 336 кг.

ART.

KINGKONG02

1.112

## PANTAGRUEL

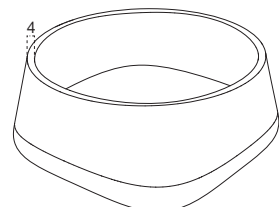
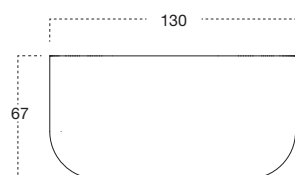

IT - **Peso lordo: 594 Kg ca. Peso netto: 552 Kg ca.**

EN - Gross weight: 594 Kg approx. Net weight: 552 Kg approx.

DE - Bruttogewicht: 594 Kg ca. Nettogewicht: 552 Kg ca.

FR - Poids brut: 594 Kg environ. Poids net: 552 Kg environ.

ES - Peso bruto: 594 Kg aprox. Peso neto: 552 Kg aprox.

RU - Вес брутто: ≈ 594 кг. Вес нетто: ≈ 552 кг.

ART.

PANTAGRUEL01

1.620





**antoniolupi**

**73**

VIA MAZZINI

**75**

Antonio Lupi Design S.p.A.  
via Mazzini 73/75 - 50050 Stabbia  
Cerreto Guidi (Firenze) - Italy  
T +39 0571 586881\_95651  
F +39 0571 586885  
[www.antoniolupi.it](http://www.antoniolupi.it)  
[lupi@antoniolupi.it](mailto:lupi@antoniolupi.it)



