

PRIANERA®
HANDMADE IN ITALY

_ PRIA_NERA

Un Brand deve avere una storia, un messaggio autentico da

comunicare. Pria Nera è il nome originario della **matita**, comparso per la prima volta in Italia nel Quattrocento. A partire dal secondo Quattrocento, nel Nord e Centro Italia, ebbe particolare successo la matita nera, chiamata anche **"pietra nera"** o "pietra d'Italia", un materiale naturale (scisto argilloso o carbonifero) proveniente dai giacimenti del Piemonte, già citato dal pittore Cennino di Andrea Cennini (Colle di Val d'Elsa, 1370 – Firenze, 1440) nel suo trattato sulla pittura "Il Libro dell'arte", risalente all'inizio del XV secolo.

"Ancora per disegnare ho trovata certa pria nera, che vien del Piemonte, la quale è tenera pria; e puo'la aguzzare con coltellino, chè ella è tenera e ben negra; e puoi ridurla a quella perfezione che 'l carbone. E disegna secondo che vuoi".

La vera bellezza è quella creata dalla mente e realizzata con le mani. Nella collezione Prianera la matita creativa del designer, diventa la matita esperta del modellista nel creare sagome di cartone per ogni modello, e ancora la matita attenta dell'artigiano nel trasferire ogni sagoma sui manti delle migliori pelli. Stile, unicità, ricerca, tradizione, innovazione, in una cornice tutta italiana.

Questo è Prianera.

A Brand must have a story, an authentic message to tell. Pria Nera is the original name of the pencil, used for the first time in Italy in the XV century. From the second part of the XV century in the North-Central area of Italy the black pencil, also called "pietra nera" (black stone), obtained a great success.

It was natural coal coming from the fields of the region Piemonte, also mentioned in the essay about painting "Il Libro dell'Arte" (the book of the art) written by the Italian painter Cennino di Andrea Cennini:

"I found a black stone (pria nera), from the region of Piemonte, it is a soft stone, which you can shape with a little knife, it's black and you can perfectly model it to design as you want".

In Prianera collection the pencil expresses our creative and high quality artisanal process: the creativity of the designer pencil creating new models continues in the experience of the modeller pencil creating the cardboard cutouts composing each model. Then the care of the artisan pencil follows these cutouts to select the best parts of each leather. The real beauty is the one created by the mind and carried out by hands. Style, research, tradition, innovation, in a whole Italian setting.

This is Prianera.



Allegoria dell'abbondanza - Sandro Botticelli | 1480 - 1485, inchiostro e pietra nera - British Museum, Londra
 Allegory of Abundance - Sandro Botticelli | 1480 - 1485, ink and black stone - British Museum, London

_ 47122, FORLÌ

Forlì è uno dei più importanti distretti d'Italia nella produ-

zione di divani, poltrone e imbottiti, ed è qui che si collocano azienda e showroom. Prianera è un marchio di livello internazionale, ma fortemente radicato nel territorio con la consapevolezza delle proprie origini e la capacità di guardare il futuro con l'eccellenza sempre al primo posto. Prianera è senso di appartenenza, Prianera è produzione **100% Made in Italy**, con grande attenzione per i dettagli e amore per i materiali di qualità. Lo showroom Prianera, firmato da Giorgio Ragazzini, ha uno spirito unico ed evolutivo, in sintonia con la **modernità** e fedele ai propri principi stilistici fatti di proporzioni misurate, equilibrio estetico e lusso sofisticato.

Prianera headquarters and showroom are in Forlì, where the global brand has its roots. Forlì is one of the most important district in Italy for the production of sofas, armchairs and upholstered furniture. Prianera is sense of belonging, is a **100% Made in Italy** production with attention to detail and love for quality material. With culture of production with creativity and excellence, the brand reflects not only the company's roots but also its future. Prianera Showroom, designed by Giorgio Ragazzini, is an experience in the Brand's long standing tradition with an unique and evolutionary style, in harmony with the **modernity** and faithful to its stylistic principles.



_ DESIGN

La costante ricerca e il contributo di famosi designers rendono unico e inconfondibile lo stile contemporaneo di Prianera. La gamma

di prodotti nella collezione Prianera trova il suo tratto distintivo nella stretta connessione con la **modernità**, mostrando la capacità di comprendere i bisogni e i trends del pubblico internazionale. Uno degli elementi che determina la crescita e il successo di Prianera sta nel contributo creativo di rinomati **designers**, che collaborano con l'azienda, come: Carlo Bimbi, Fabrizio Ballardini, Giorgio Ragazzini, Elena Arkhipova, Rino Dalmonte, Angelo Tomaiuolo ed Enrico Cesana.

Constant research and the contribution of famous designers make Prianera contemporary style unique and unmistakable. The range of products in the Prianera collection has its distinctive feature in its tight connection with **modernity**, showing its strong ability to understand the needs and trends of an international public. One of the main elements that determine the growth and success of Prianera lies in the creative contribution of many renowned **designers**, who have been collaborating with the company, such as Carlo Bimbi, Fabrizio Ballardini, Giorgio Ragazzini, Elena Arkhipova, Rino Dalmonte, Angelo Tomaiuolo and Enrico Cesana.



_ HANDCRAFT

Prianera si dedica alla quotidiana ricerca dell'equilibrio

tra la bellezza del lavoro eseguito a mano, secondo la **tradizione**, e l'affidabilità del ricorso alle più **moderne tecnologie**. Ogni cucitura ed ogni piega sono lavorati con maestria per ottenere il miglior risultato possibile e per la valorizzazione del prodotto italiano nel mercato globale. Esperti tagliatori, tappezzieri e sarte si impegnano giornalmente nella produzione senza lasciare nulla al caso, soprattutto senza trascurare tutti quei piccoli **dettagli** che contraddistinguono i prodotti Prianera.

Prianera dedicates an unceasing activity to the daily research for balance between the beauty of work made by hand according to **tradition**, and the undeniable advantage and reliability of the **latest technologies**. Every single stitching and every single fold are masterly crafted in order to obtain the best possible result. Each model is emblem of the commitment of the company to give value to the Italian product on the global market. With expertise, care and constant research Prianera represents the long experience of a production that is synonym for high quality and Italian style. Skilled hands work hard every day on the production, leaving nothing to chance and, above all, without neglecting all those **details** that distinguish the Prianera products. Every piece is a unique masterpiece.

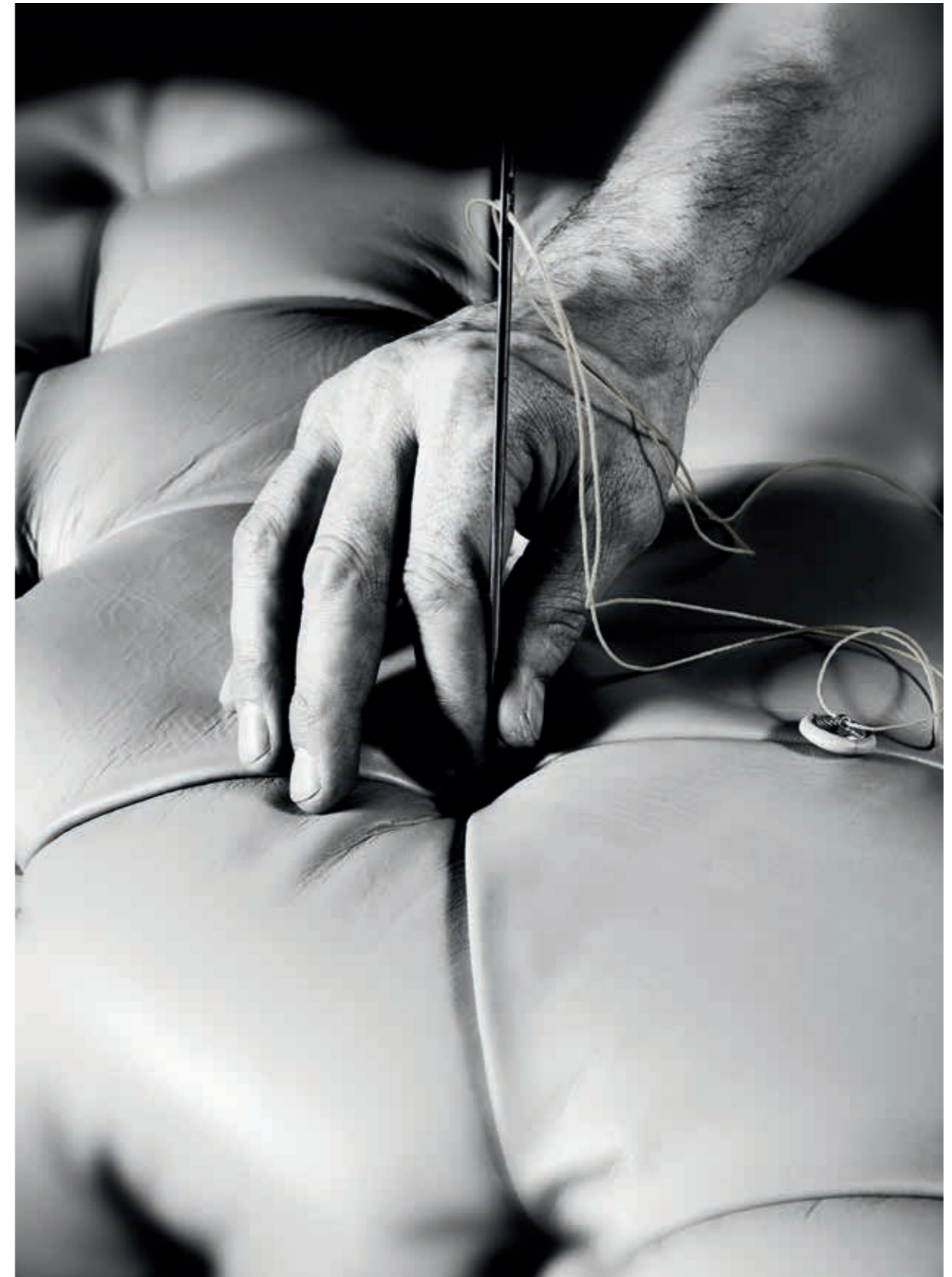
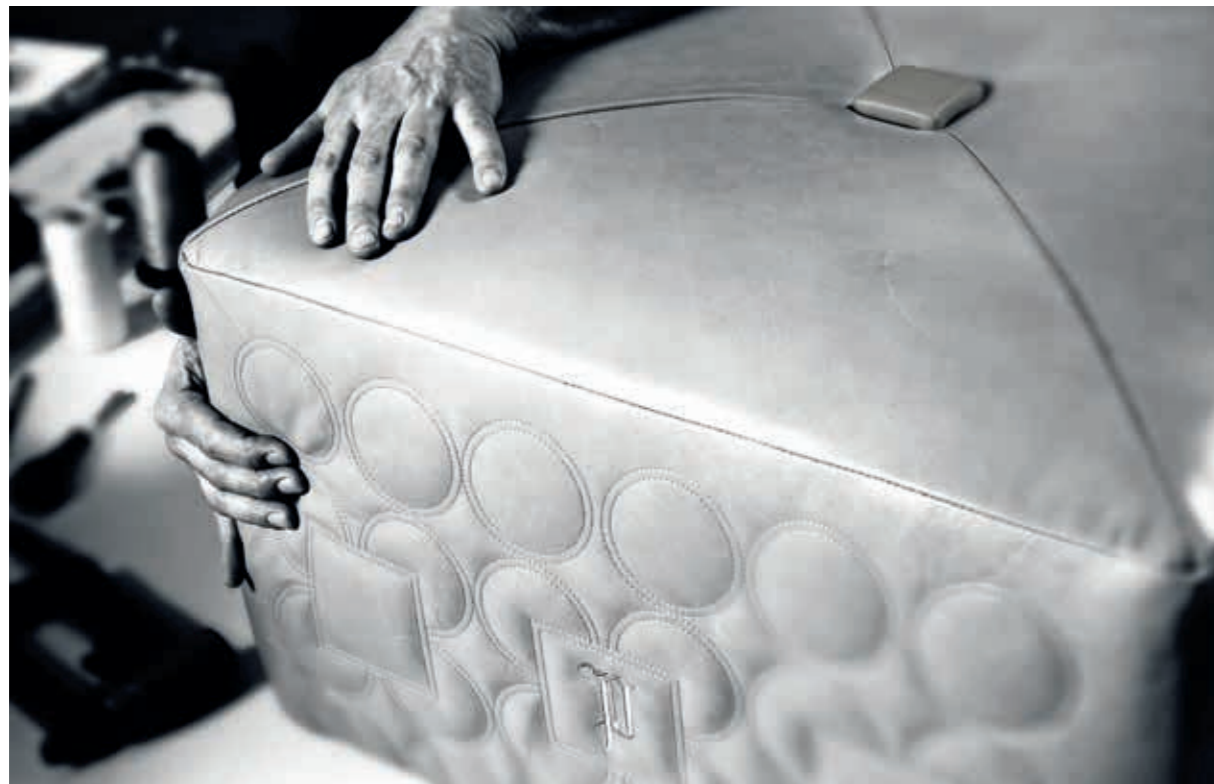

_ INDEX



12
_ Dumbo



22
_ Pook



34
_ Palco



130
_ Maya



138
_ Modì



144
_ Malaga



50
_ Odeon



66
_ Odeon Love Seat



74
_ Altair



152
_ Aliante



160
_ Bernini



168
_ Glamour



80
_ Sharpei



92
_ Sonora



98
_ Ariel



174
_ Josef



180
_ Sorrentino



186
_ Armchairs



106
_ Mood



114
_ Nesting



124
_ Tangram Up



198
_ Coffee Tables



202
_ Complements

_ DUMBO

La ricerca di un ideale rapporto tra forma e funzione, collocato in uno spazio

temporale non definito atto a mantenere un'armoniosa relazione tra le sedute e la zona ad esse destinata, ha dato vita a questo progetto. Dumbo, nasce nel 1992 da un progetto di Rino Dalmonte.

Prianera presenta questo modello nella sua veste originale.

This project is born to search for an ideal connection between form and function, placed in an undefined space and time to keep an harmonious relationship between the seats and the area where they will be. Dumbo was born in 1992 from a project of Rino Dalmonte.

Prianera presents this model in its original form.







Dumbo sofa & armchair in fabric Sambuco color 19



Dumbo sofa in leather Posh color Carioca 22



Dumbo armchair in fabric Sambuco color 101
I Piani coffee table with Calacatta marble top & Titanio finishing

– PEANUTS & NUTS Ideale complemento del modello Dumbo, i complementi Peanuts & Nuts aggiungono uno sguardo ludico a questa iconica collezione.

Model Dumbo ideal complements, Peanuts and Nuts give a further elegant touch to this exclusive collection.



Peanuts coffee table in fabric Sambuco color 19 with metal top
Nuts ottoman in leather Posh color Carioca 22

_ POOK

Pook è la parte rassicurante che ognuno si aspetta tornando a casa. Semplicità e accoglienza.

La sua personalità si esprime con piani obliqui che ne fanno un divano diversamente uguale.

Pook is the reassuring part that everybody expects coming back home. Style and comfort. Its personality is expressed through oblique planes, which make it a extremely elegant sofa.









Blendy coffee table high in leather Diamante color Cemento 5209 & Titanio finishing
Blendy coffee table low in leather Posh color Cognac 19 & Titanio finishing



Pook sofa in leather Diamante color Cemento 5209



Pook sofa in leather Diamante
color Cemento 5209
Coffee Sak in leather Diamante
color Cemento 5209
& Noce Canaletto top
/ Onice Tanzania top
Pouf Sak in leather Diamante
color Cemento 5209
Setoso Carpet color bianco-avorio 01





– MINIPOOK Minipook manifesta un nuovo atteggiamento dei complementi, che li rende interpreti della scena, fino ad essere volutamente protagonisti. Completano questo ambiente le cornici Vivian e i vasi Glove.

Minipook creates a new mood for complements, they take the scene becoming protagonist. In this ambient also Vivian Frames and Gloves vases.



Minipook armchair | design Fabrizio Ballardini

— PALCO

Un tratto pulito e deciso disegna il comfort della seduta, definita dallo spessore generoso e dalla continuità con l'imbottitura del bracciolo. Nasce una collezione composta da divani, elementi accostabili, chaise longue, poltrona e pouf, destinata ad un piacevole utilizzo quotidiano.

Net and accurate lines design the comfort of the seat with a generous thickness which ends in the arm. A star is born. A complete collection with sofas, lateral elements, chaise, armchair and ottoman, for a everyday pleasure.

Net and accurate lines design the comfort of the seat with a generous thickness which ends in the arm. A star is born. A complete collection with sofas, lateral elements, chaise, armchair and ottoman, for a everyday pleasure.



Palco sofa in leather Covenant color Kaki C402
I Piani coffee table with Port Laurent marble top & Titanio finishing
Op 01 carpet in 100% New Zealand wool, hand tuft







Palco sofa in leather Covenant color Kaki C402
Pinch pillow in leather Covenant color Kaki C402 & color Olive C458 belt



– TOSCA ARMCHAIR Una poltrona dalle proporzioni equilibrate, enfatizzate dalle particolari cuciture. Il suo rigore è reso accogliente dalla soffice imbottitura, le sue forme lineari e rassicuranti fanno di Tosca, un best seller.

Tosca is a piece of art in three different ways: the softness of the enveloping comfort is enhanced by the soft folds of leather and fabric, the sinuosity and elegance of the lines give a unique and unmistakable style and the versatility in upholsteries and finishings gives it always new shades and lives.



Tosca armchair in leather Posh color Carioca 22
I Piani coffee table with Port Laurent marble top & Titanio finishing
Vivian frame in leather Posh color Carioca 22

– PALCO SOFA Il divano Palco a tre posti, rivestito in pelle Covenant colore Kaki, dialoga con il tappeto Novecento, entrambi disegnati da Giorgio Ragazzini, creando un'armonia di forme e colori ispirati all'architettura italiana del '900.

Palco sofa upholstered in leather Covenant color Kaki and Novecento carpet create the perfect mix. Both products are designed by Giorgio Ragazzini and make an elegant harmony with shapes and colors taking inspiration from the Italian architecture of the twentieth century.



I Piani coffee table with Calacatta marble top & Titanio finishing
Novecento carpet in 100% New Zealand wool, hand tuft





Palco sofa in leather Covenant color Kaki C402



Blency coffee table high in leather Covenant color Kaki C402, Olive C458, Cenere C486 & Titanio finishing
Blency coffee table low in leather Covenant color Kaki C402, Olive C458, Cenere C486 & Titanio finishing



Alice armchair in Gemma color quilted velvet 29 & Sambuco fabric color 29
Blendy coffee table with Calacatta marble top & Titanio finishing
Vivian frame in leather Diamante color Cemento 5209

_ ODEON

Sul piano delle radici culturali, moda e design sono assai simili, almeno da tre

punti di vista: la "cultura d'uso", la "cultura imprenditoriale" e la "cultura manifatturiera". Queste radici avvicinano questi due mondi che, sempre più spesso, condividono spazi comuni di sviluppo ma anche di comunicazione e promozione. In particolare, nelle collezioni Odeon il binomio "moda e design" viene richiamato dall'osmosi delle lavorazioni, dei materiali e dell'attenzione ai dettagli, peculiari della cultura e tradizione italiana.

Considering cultural roots, fashion and design are very similar at least from three points of view: "the culture of use", the "firm culture" and the "manufacturing culture". These roots put in contact these two worlds that more and more often share common spaces of development, communication and promotion. In particular in the Odeon collection the couple "fashion and design" is recalled through the union of manufacturing processes, materials and attention to detail that is peculiar of the Italian culture and tradition.









Odeon sofa in leather Diamante color Amianto 5208
Giglio coffee table in Port Laurent marble top & Matte Black finishing
Vivian frame in leather Stonewash color Winter Blu 6016





Opera sofa in leather Posh color Savana 17



Opera coffee table in Port Laurent marble top & gold finishing
Ouverture bookcase in Noce Canaletto wood

– ODEON ARMCHAIR Disponibile in due differenti altezze, la poltrona Odeon è caratterizzata dal disegno asimmetrico degli schienali, in questa versione, rivestiti in velluto arricciato a mano.

Available in two different heights, Odeon armchair has a unique asymmetrical design. In this version is in velvet carefully hand folded.



Odeon armchair in Sambuco fabric color 130



Odeon Sofa in leather Stonewash Pro color winter blu 6016
with piping in Sambuco fabric color 130



– **ODEON LOVE SEAT** Il contrasto

raffinato delle due pelli arricciate a mano caratterizza la Love seat Odeon, che con le sue proporzioni inusuali suggerisce un utilizzo libero, disinvolto e fuori dagli schemi.

The elegant contrast of the hand folded leathers enriches the Odeon Love seat, from this mix an unconventional charm is born.









Odeon love seat in leather Madison
color Luna M403 & Cenere M486
Altair sofa in leather Madison
color Cenere M486
Passepartout ottomans in leather Posh
color Carioca 22 & Madison color Cenere M486
with piping and botton in
leather Posh color Carioca 22
Blendy coffee table with Nero Marquinia
marble top & Titanio finishing
Vivian frame in leather Posh
color Carioca 22
Op 01 carpet in 100% New Zealand wool, hand tuft
Erica carpet color Fumo 177



_ ALTAIR

Eleganza formale, comfort, un'ampia articolazione che permette grande flessibilità

di utilizzo sono le caratteristiche di questo modello. Divani in diverse dimensioni, elementi angolari, comodi terminali, il tutto caratterizzato dal basamento a vista in acciaio che solleva le sedute da terra e ne definisce il design leggero e contemporaneo: tutto questo è Altair.

Formal elegance, comfort, a wide choice of elements to allow use flexibility, are the topics of this model. Sofas in different dimensions, corner elements, comfortable terminals, all characterized by the evident steel base that lifts the seats from floor and defines their contemporary and light design: all this is Altair.





Altair sofa in leather Saddle color nero 6050

– **SADDLE LEATHER** Saddle è una pelle a pieno fiore finemente lavorata, appositamente trattata per mantenere le caratteristiche delle pelli di alta qualità e per mettere in risalto il suo grande spessore. Il risultato è un aspetto lussuoso, liscio e opaco.

Saddle leather is a finely worked full grain leather, specially treated to retain the characteristics and features of top quality leather by enhancing its great thickness. The result is a luxurious smooth and matte look.



Altair sofa in leather Posh color terra bruciata 27



_ SHARPEI

Sharpei si propone come una vera isola del

relax, dalle forme morbide e rassicuranti, presenza ideale in spazi ampi in cui è richiesta una tipologia di seduta dalla forte presenza scenica. Particolare è il rapporto fra i volumi importanti della struttura ed i cuscini più sottili che si integrano in virtù della morbidezza di questi ultimi.

Sharpei is a real relax island, with soft and comforting lines, its ideal placing is in large spaces where are requested seats with strong scenic presence. The relation is particular between structure big volumes and the thin cushions that perfectly integrates in the sofa thanks to their softness.







Sharpei sofa in leather Posh
color blu notte 18
Sharpei tray in wood
color wengè



Sharpei sofa in leather Georgia color calcare 9043
Nora armchair in leather Georgia color acacia 9009





Sharpei sofa in Primula fabric
color 01
Sharpei tray in wood
color wengè



Sharpei sofa in leather Georgia color calcare 9043



_ SONORA

Le ampie proporzioni del divano Sonora assumono una valenza carica di rimandi alla tradizione artigianale. Sia i rivestimenti in pelle che quelli in tessuto aggiungono qualità espressiva alle linee essenziali, ma non banali, di questa collezione che consente di configurare infinite soluzioni formali.

The roomy proportion of Yucatan sofa, assume a worthiness full of references to the craftsmanship tradition. Both leather and fabric covers add an expressive quality to the essential lines, but not featureless, of this collection, that allows many combination and solution.

Sonora sofa | design Fabrizio Ballardini





Sonora sofa in leather Bosphore color nuvola 1516



— ARIEL

Questo sistema di sedute è caratterizzato dalle linee essenziali degli elementi

che sono però dotati di un meccanismo attraverso il quale è possibile, sollevando semplicemente la parte posteriore, modificare l'altezza degli schienali per ottenere una differente tipologia di comfort, con il completo appoggio delle spalle e della testa. La leggerezza dell'insieme è accentuata dall'aereo basamento in metallo.

This seat system is characterized by the essential lines of elements, that are equipped with a mechanism that allows the back height changing by simply lifting the rear, to get a different comfort with the whole support of head and shoulder. The lightness of this model enhanced by the aerial metal base.



Ariel sofa in Primula fabric color 01





Ariel sofa in leather Georgia color elefante 9016





_ MOOD

La declinazione di un'idea che diventa un progetto. Linee semplici, bracciolo

sottile, volumi importanti, il tutto interpretando con estrema morbidezza le superfici e la lavorazione dal caratteristico disegno a quadri. Molteplici varianti in larghezza e profondità consentono poi di ottenere altrettante combinazioni d'uso.

An idea that becomes a project. Simple lines, thin arms, important volumes, the typical tufting design is rendered with extreme softness. Multiple choices of depth and width allow a wide range of combination.



– GEORGIA LEATHER Pelle naturale estremamente morbida. La grana naturale, leggermente irregolare e l'aspetto opaco esaltano la bellezza e la versatilità di questa straordinaria pelle. Il divano Mood è rivestito in pelle Georgia colore calcare 9043.

Extremely soft natural leather. The natural and slightly irregular grain and the matte look enhance the beauty and the versatility of this amazing leather. Mood sofa in leather Georgia color calcare 9043.





_ POSH LEATHER

Prianera Posh vanta una vasta selezione di colori esclusivi per un'esperienza unica al tatto. I segni di crescita, le cicatrici e tutti i fattori naturali che hanno influenzato la pelle fanno parte del suo aspetto, la variazione di colore da manto a manto è parte dell'anima di questa pelle. Il divano Mood è rivestito in pelle Posh colore menta 24.

Prianera Posh boasts a wide selection of exclusive colors for a unique velvety touch experience. Growth mark, healed scars and all natural factors that have influenced the hide are part of the look, color variation from hide to hide is part of the soul of this leather. Mood sofa in leather Posh color menta 24.



_ **NESTING**

Reinterpreta il concetto di informalità. Con

linee pulite, un design contemporaneo, forme generose che trasmettono un senso di comfort reale, da "toccare con mano" Nesting è disponibile in un'ampia gamma di dimensioni, anche in una particolare versione con seduta più profonda, per un relax totale.

It reinterprets the concept of informality. Essential lines, contemporary design, wide shapes that give a real comfort sensation to be "touched", Nesting is available in a wide range of dimensions and in a particular version with deeper seat, for a total relax.





Nesting sofa in leather Posh color savana 17

Nesting armchair in leather Posh color menta 24





Nesting sofa in leather Georgia color latte 9000





Nesting sofa & armchair in leather Madison color ray M429

_ TANGRAM UP

Sistema di divani sia accostabili

che fissi, definiti da volumi sospesi su piedi in metallo, all'insegna della leggerezza. Con Tangram Up si possono realizzare combinazioni lineari, angolari o terminali, con rivestimenti sia in pelle che in tessuto, sempre con la qualità e la cura del dettaglio di Prianera.

Modular elements that can be put close or be fixed, with volumes suspended on metal feet, with a concept of lightness.

With Tangram Up different combinations are possible, linear, sectional or terminal, with fabric or leather upholstery, always with the quality and the care for the detail typical from Prianera.





Tangram Up sofa in leather Covenant color castagno C417



— MAYA

Giocato su linee arrotondate e dimensioni misurate, Maya è un divano accogliente che suggerisce, con eleganza, calore e familiarità. La sua versatilità consente anche di utilizzare materiali abbinati, come pelle e tessuto, per arricchire il rivestimento.

Played on rounded forms and measured size, Maya is a cozy sofa which elegantly suggests warmth and familiarity. Its versatility allows to use combined materials, such as leather and fabric, to enrich its cover.







Maya sofa in leather Stonewash Pro color ecrù 6002 & 177 Magnolia fabric color 10



Maya sofa in leather Georgia color calcare 9043



_ MODÌ

Con un facile movimento Modì offre diverse posizioni dello schienale per un

comfort personalizzabile. Accogliente e amichevole, grazie alla sua semplice modularità, può dar vita a una ampia serie di composizioni.

With an easy movement Modì has adjustable back cushion with many positions for a customizable comfort. Cozy and amicable, thanks to its simple modularity, allows a wide range of combinations.







Modi sofa in leather Stonewash Pro color ecrù 6002

— MALAGA

Il comfort prima di tutto, ma senza rinunciare ad

eleganza e lusso grazie alla preziosa lavorazione trapuntata su tutte le sedute. Grazie al meccanismo posizionato negli schienali è possibile modificare l'inclinazione per adattare l'utilizzo del divano alle differenti esigenze di convivialità o totale relax.

Comfort first, without renounce to elegance and luxury, thanks to quilted manufacturing on all seats. Thanks to the mechanisms placed in the backs is possible to change the inclination, to adapt the sofa to the different conviviality or total relax needs.







Malaga sofa in leather Covenant color kaki C402
Florence armchair in Sambuco fabric color 20



Malaga sofa in leather Georgia
color latte 9000



_ ALIANTE

La vera essenza della modernità. Aliante

è una collezione di imbottiti che integra alla perfezione gli elementi componibili e ne moltiplica le possibilità di configurazione ed utilizzo. Grazie poi agli schienali regolabili in diverse posizioni, anche nell'elemento angolare, Aliante è progettato per differenti opzioni di comfort.

The real essence of modernity. Aliante is a collection that perfectly integrates the modular elements and multiply the configuration possibilities. The back can be adjusted in different positions, even in the corner element, this model is conceived for different comfort options.







Aliante sofa in leather Georgia color scoglio 9044 with piping in Sambuco fabric color 48



Aliante sofa in leather Covenant color castagno C417 with piping in Magnolia fabric 05

_ BERNINI

Bernini è una collezione di divani caratterizzata

zata dalla struttura aerea, leggera e lineare, poggiata su piedi a slitta metallici in svariate finiture, che sostiene i soffici ed abbondanti cuscini di seduta ed i braccioli generosi. Il contrasto tra elementi portanti rigidi e sottili e la morbidezza delle cuscinate rendono Bernini un modello contemporaneo di grande comfort.

Bernini is a sofa collection characterized by a airy, light and linear frame, laid on metal sled legs, available in many finishings, which support soft and plenty seat cushions and generous armrests. The contrast between rigid and thin supporting elements and the softness of the cushions makes Bernini a contemporary model with huge comfort.







Bernini sofa in leather Bosphore color white 1513



Bernini sofa in leather Stonewash Pro color argento 6015

_ GLAMOUR

L'altezza generosa degli schienali consente un confortevole appoggio delle spalle e della testa. La forma accogliente della struttura invita ad un relax totale. Glamour rivisita in chiave contemporanea forme senza tempo, senza sacrificare, alla moda delle linee minimali, il vero comfort dei divani di famiglia.

The high back assures a comfortable rest to head and shoulders. The cosy shape of the structure invites to a total relax. Glamour revisits in a contemporary key timeless lines, without sacrifice to minimal form trend, the real comfort of the family sofa.



Glamour sofa in leather Bosphore color white 1513





_ JOSEF

Contraddistinto dal particolare design dell'angolo fra schienale e

bracciolo, Josef è un sistema di sedute, fisse e componibili, capace di dare vita ad una vastissima gamma di soluzioni d'arredo. La sua forma particolare, insieme all'altezza più "decisa" dello schienale, lo rendono estremamente comodo e confortevole.

This model is marked by a particular design of the corner between back and arm. Josef is both a fixed and modular seats system that can create a wide range of combination. The particular shape, together with the high back, gives to this model a great comfort.





Josef sofa in leather Stonewash Pro color deer 6033



Josef sofa in leather Georgia color bird 9018

_ **SORRENTINO**

Il divano componibile Sorrentino è concepito per unire design e comfort. Moderno ed essenziale, con linee definite e poggiatesta regolabili, garantisce un comfort elevato grazie ai movimenti relax elettrici e agli accessori dell'elemento centrale a trapezio. Il piede a slitta in metallo, disponibile in svariate finiture, ne esalta l'eleganza. In pelle e tessuto, in diverse misure e soluzioni, si adatta facilmente al vostro living.

Sorrentino sectional sofa is conceived for combine design and comfort. Modern and essential, with well-defined lines and adjustable headrests, ensure an high comfort thanks to the electric relax mechanisms and the accessories of the trapezoidal central element. The metal sled legs, available in many finishings, enhance its elegance. In leather or fabric, in different sizes and solutions, it will easily fit in your living room.





Sorrentino sofa in leather Bosphore color taupe 1504
Karen armchair in leather Posh color blu notte 18





– ARMCHAIRS

Una collezione completa di proposte che parte da forme semplici e lineari, caratterizzate da pulizia formale e dettagli rifiniti con cura artigianale, fino ad arrivare a vere e proprie ricerche progettuali che giocano con le strutture, le proporzioni, i volumi, all'insegna della creatività e dell'innovazione. Tutte le poltroncine Prianera si accostano senza problemi ai divani della collezione.

A complete collection, that starts from linear and simple lines, characterized by neat shapes and details manufactured with great care, up to real project research that plays with structures, proportions, volumes. All Prianera armchairs can match without problems to all sofas.



– MINIPOOK



Minipook armchair in leather Posh color Cognac 19

– ALICE

Alice armchair | design Carlo Bimbi



Alice armchair in Gemma color quilted velvet 29 & Sambuco fabric color 29

– ODEON

Odeon armchair | design Giorgio Ragazzini



Odeon armchair in Sambuco fabric color 130

– TOSCA

Tosca armchair | design Carlo Bimbi



Tosca armchair in leather Posh color Carioca 22

– KAREN

Karen armchair | design Carlo Bimbi



Karen armchair in leather Posh color blu notte 18

– FLORENCE

– WEBY

Florence armchair | design Style Department Prianera



Florence armchair in fabric Sambuco color 20

Weby armchair | design Fabrizio Ballardini



Weby armchair in leather Madison color black M450

– KLAB

Klab armchair | design design Carlo Bimbi



Klab armchair in leather Posh color Terra Bruciata 27

– NORA

Nora armchair | design Fabrizio Ballardini



Nora armchair in leather Madison color ray M429

– ZOE

Zoe armchair | design Carlo Bimbi



Zoe armchair in fabric Sambuco color 20

– LOTO

Loto armchair | design Carlo Bimbi



Loto armchair in leather Georgia color Bird 9018

– I PIANI Collezione di tavolini in acciaio e marmo. I Piani rappresentano la forma connessa attraverso materie e dimensioni che sfociano in un armonico percorso di incastri.

Coffee tables collection in iron and marble. The form is connected by materials and dimensions in an harmonic path of bonds.

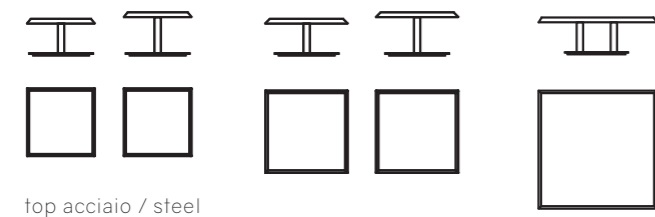

top acciaio / steel

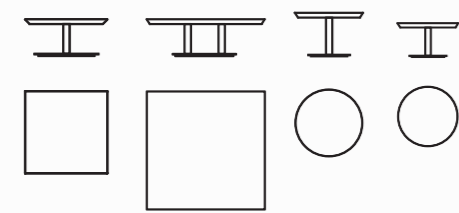

top marmo / marble

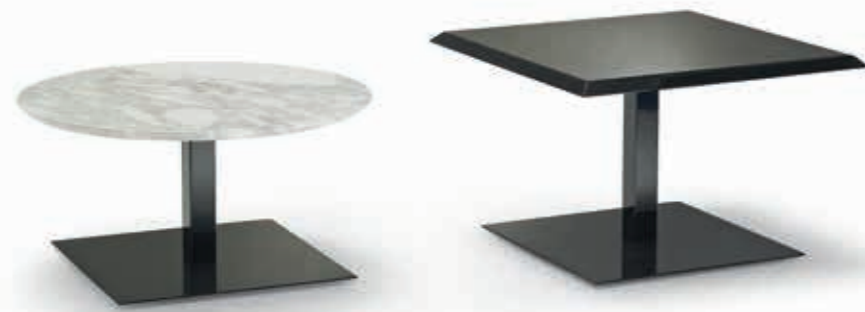

– BLENDY Una collezione completa di tavolini in due altezze. Strutture in metallo e piani d'appoggio sono disponibili in molteplici finiture e forme, dai marmi più pregiati al legno, oppure nelle pelli di Prianera.

A complete coffee tables collection with two heights. Metal structures and tops are available in many finishings and many shapes, from the finest marbles to the wood or upholstered with the exclusive Prianera leathers.

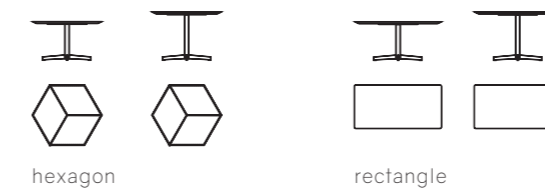

hexagon

rectangle

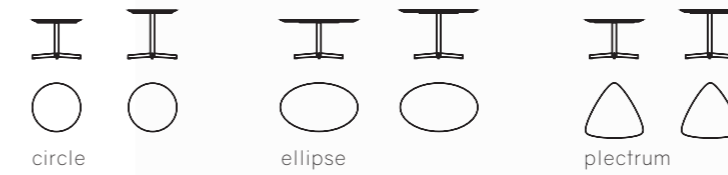

circle

ellipse

plectrum



– TRIAL

design Carlo Bimbi



– MAX & TRIBAS

design Carlo Bimbi



– MEMPHIS

design Style Department Prianera



– MEDEA La specchiera Medea è disponibile in tre diverse dimensioni, da appoggio a terra e da parete, sia con ricamo personalizzato che con rivestimento liscio.

Medea mirror is available in three different sizes, floor standing or wall mounted, with custom embroidery or smooth surface.

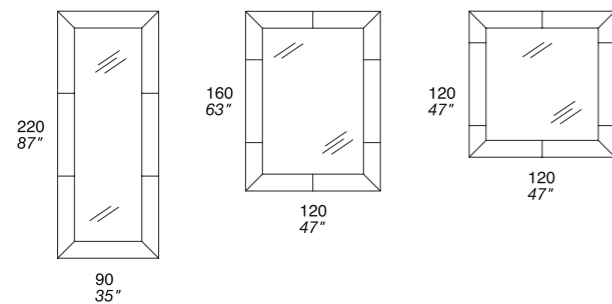

– VIVIAN Rende omaggio alla iconica tata /fotografa americana Vivian Maier. È disponibile in diverse misure ed è predisposta per ospitare le immagini del cliente o specchio.

It pays tribute to the iconic American nanny / photographer Vivian Maier. It's available in different sizes and it's designed for hosting images or mirror.

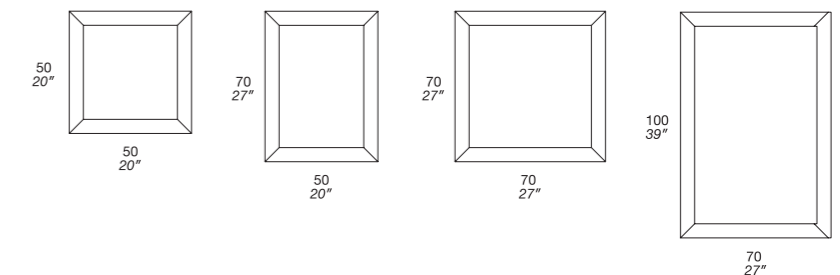

Le immagini utilizzate all'interno delle cornici Vivian nel servizio fotografico sono unicamente degli esempi. Consultare il listino per visionare le immagini disponibili. È inoltre possibile inviare il file in alta risoluzione dell'immagine che si desidera inserire all'interno della cornice.

Images used in Vivian frames for the photo shoot are just examples. Please check the available images in the pricelist. It's also possible to send HD file of a custom picture to be inserted into the frame.

– STYLE & DECOR Nel laboratorio Prianera la costante ricerca, la competenza e le tecniche danno luogo ad un progetto innovativo ed, allo stesso tempo, affondano le radici nella migliore tradizione. Da questa abilità nascono diverse collezioni di complementi, tutti intesi come elementi funzionali e ornamentali, diversi ma associabili tra di loro in modo personale ed originale.

In the Prianera Lab the constant research, expertise and technologies lead to an innovative project and, at the same time, root in the best tradition. This ability create several collections of accessories which all serve as functional elements and décor. Different but matched with each other in a personal and original way.



– CUSHION



Pinch pillow
Malva fabric color 102 & leather Stonewash Pro color dark brown 6011 belt
size: 45 x 45 cm



Pinch pillow
leather Posh color carioca 22 & Madison color cenere M486 belt
size: 45 x 45 cm



24889A
leather: Posh carioca 22
embroidery: silver
size: 35 x 55 cm

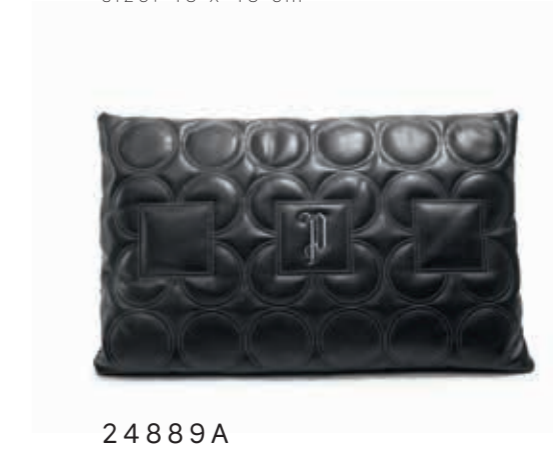

24889A
leather: Stonewash Pro antracite 6050
embroidery: silver
size: 35 x 55 cm



24889
leather: Georgia elefante 9016
embroidery: silver
size: 55 x 55 cm



24889
leather: Posh terra bruciata 27
embroidery: gold
size: 55 x 55 cm

– CUSHION



2211B
 fabric: Sambuco 19
 embroidery: tono su tono / matching
 size: 55 x 55 cm



2211B
 leather: Madison luna M403
 embroidery: silver
 size: 55 x 55 cm



24917
 leather: Posh terra bruciata 27
 embroidery: gold
 size: 55 x 55 cm



24917
 leather: Bosphore white 1513
 embroidery: tono su tono / matching
 size: 55 x 55 cm



24887B
 leather: Stonewash Pro dark brown 6011
 embroidery: rif. col. Georgia bird 9018
 size: 55 x 55 cm



24887B
 leather: Stonewash Pro forestale 6031
 embroidery: tono su tono / matching
 size: 55 x 55 cm



– CARPETS La nuova collezione di tappeti si pone come naturale complemento della gamma Prianera. Materiali di qualità lavorati in maniera impeccabile, estetica ispirata alle tendenze artistiche del '900 per accostarsi ai divani, aggiungono carattere e personalità.

New carpet collection stands as the natural complement of Prianera collection. Perfectly crafted high quality materials, aesthetic inspired to '900 artistic trends in order to suit the sofas style, by adding personality.



Op 01 carpet | design Giorgio Ragazzini

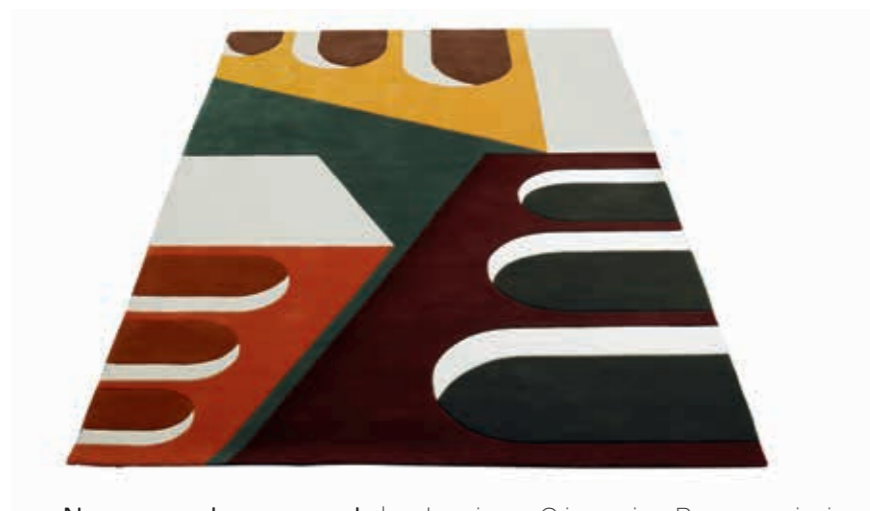

Novecento carpet | design Giorgio Ragazzini



Setoso carpet



bianco | avorio 01 avorio | nero 04 beige | marrone 02



Disegno carpet



blue night grey ebony mineral black

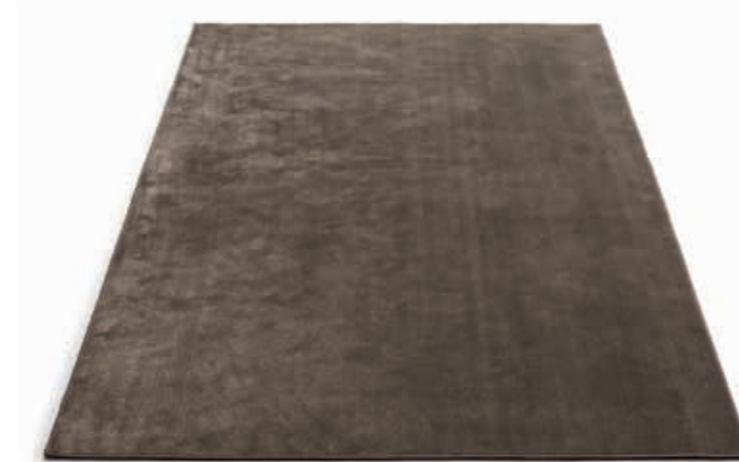

Erica



bianco 169 nebbia 172 perla 173 tortora 190 fumo 177 rosso 125 blu 186 nero 178

opzioni bordo
fettuccia in fintofilo per Erica Carpet
piping options
in ribbon for Erica Carpet

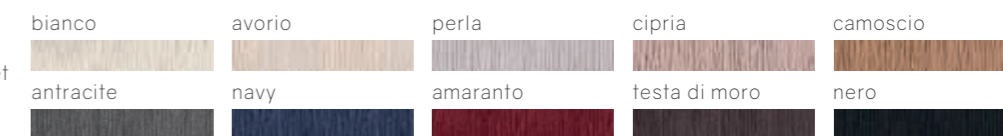

– MARBLE

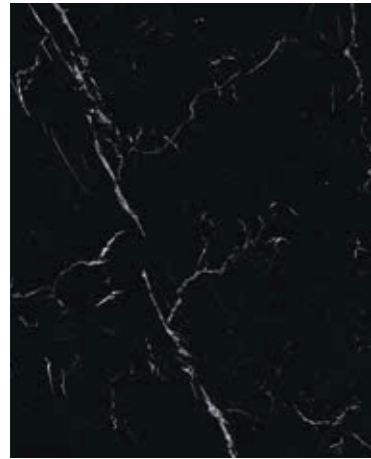

marquina



calacatta

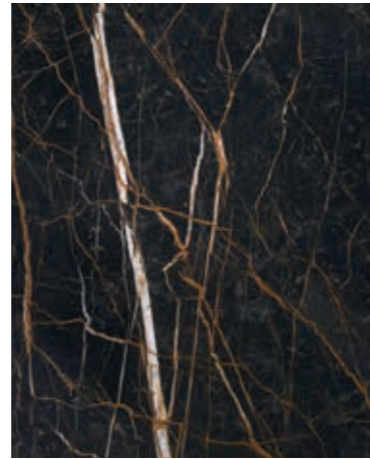

port laurent



onice tanzania

– METAL



chrome



dark chrome



titanio



nickel



gold



brass



matte black



RAL 9016



RAL 8022



dark gloss
transparent



rust

– WOOD

faggio / beech



naturale



col. talpa



col. fumè

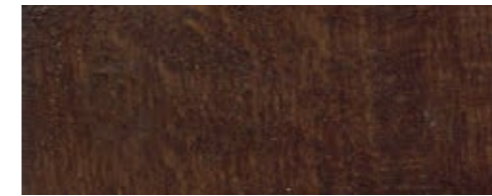

col. tabacco



col. wengè

noce canaletto



naturale

frassino / ash



col. matte grey

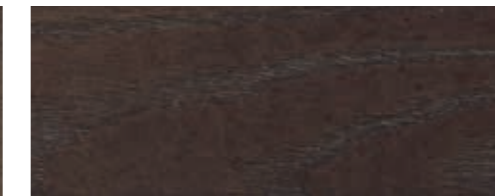

col. matte wengè



col. matte honey



col. shining grey

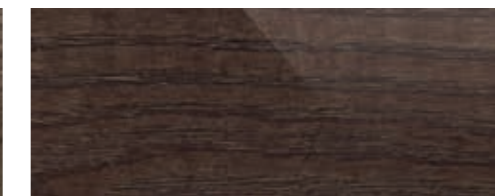

col. shining wengè



col. shining honey

– ALIANTE

design Fabrizio Ballardini

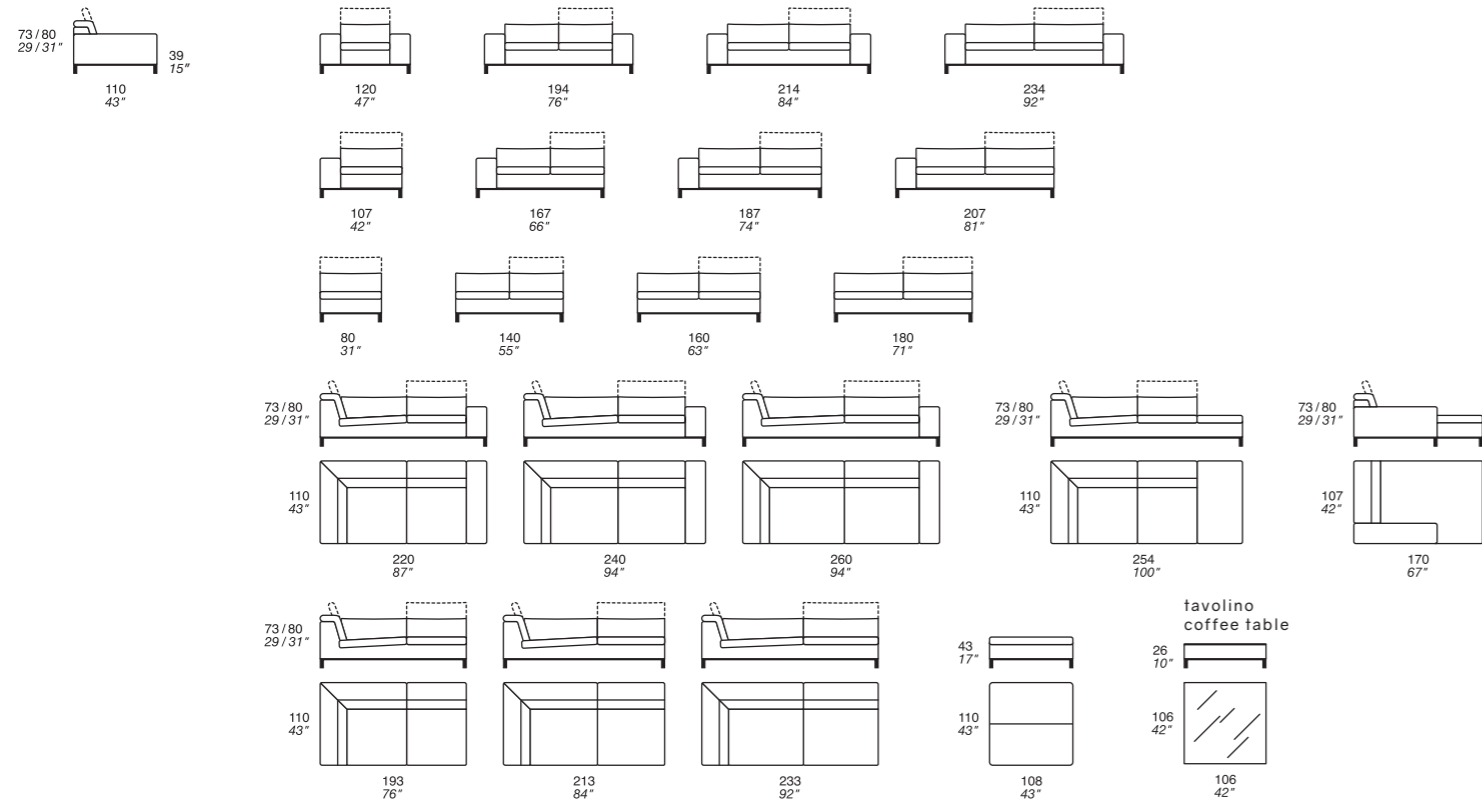

– ALTAIR

design Fabrizio Ballardini

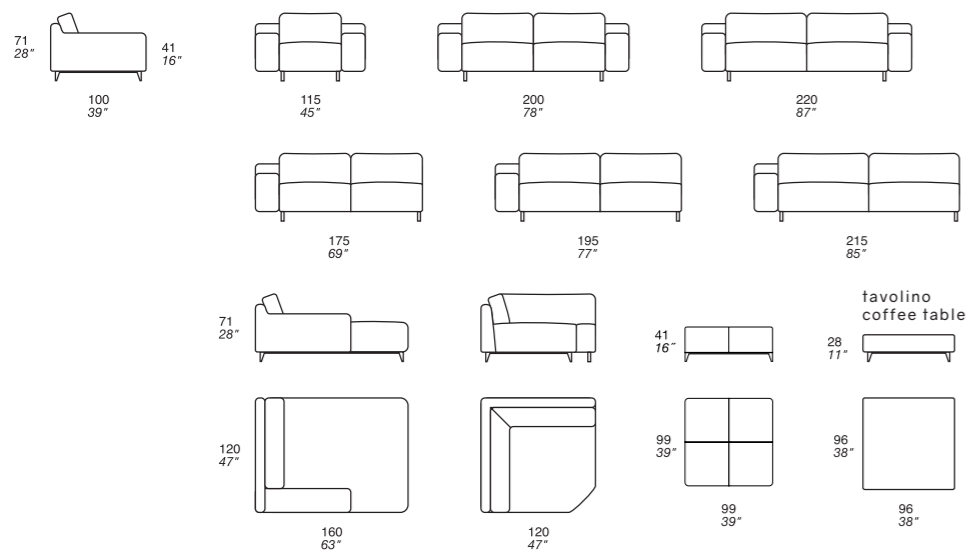

– ARIEL

design Fabrizio Ballardini

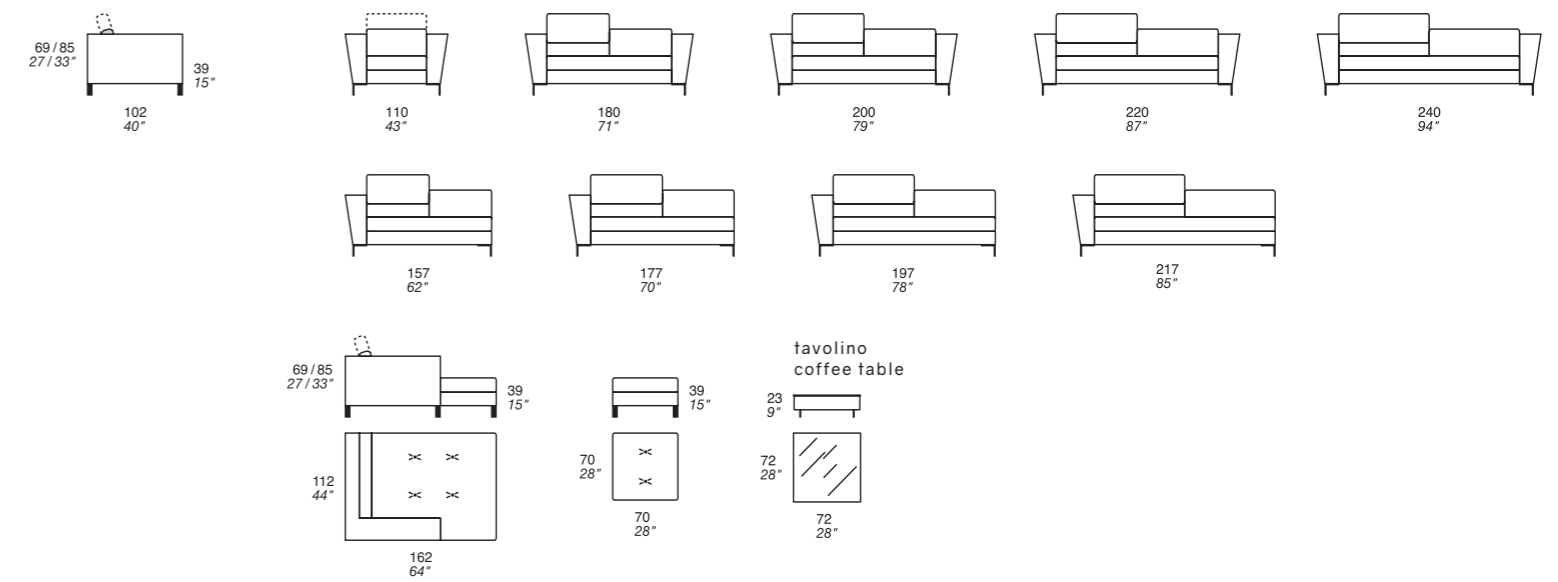

– BERNINI

design Style Department Prianera

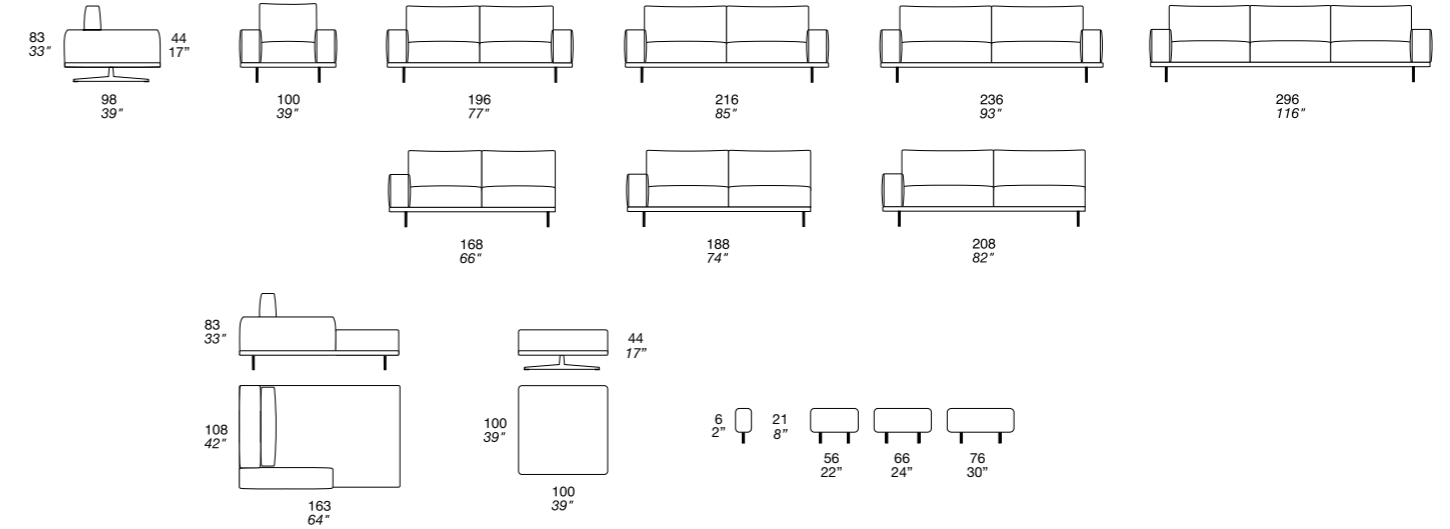

– DUMBO

design Rino Dalmone & Elena Arkhipova

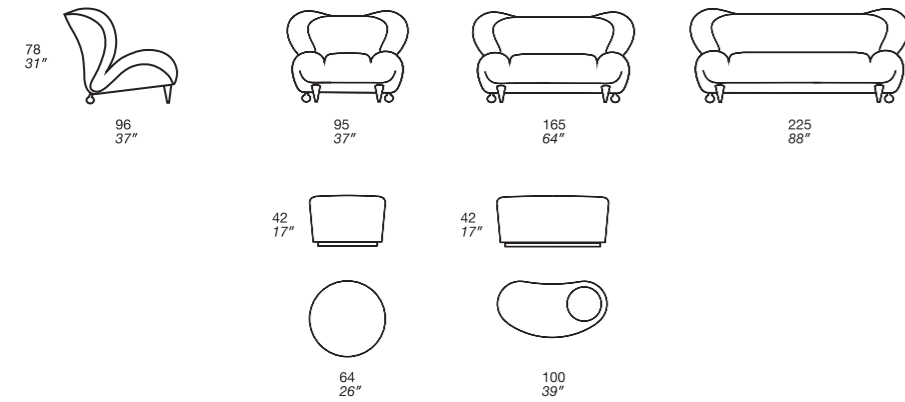

– JOSEF

design Carlo Bimbi

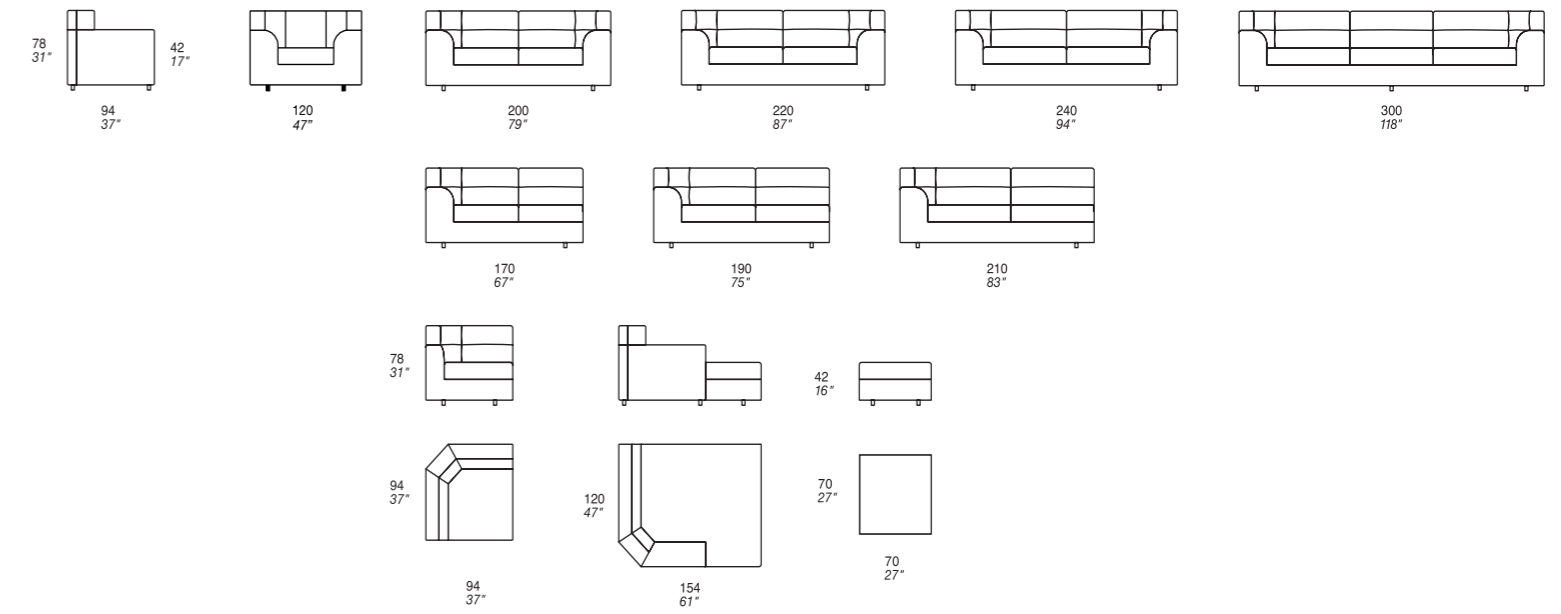

– GLAMOUR

design Carlo Bimbi

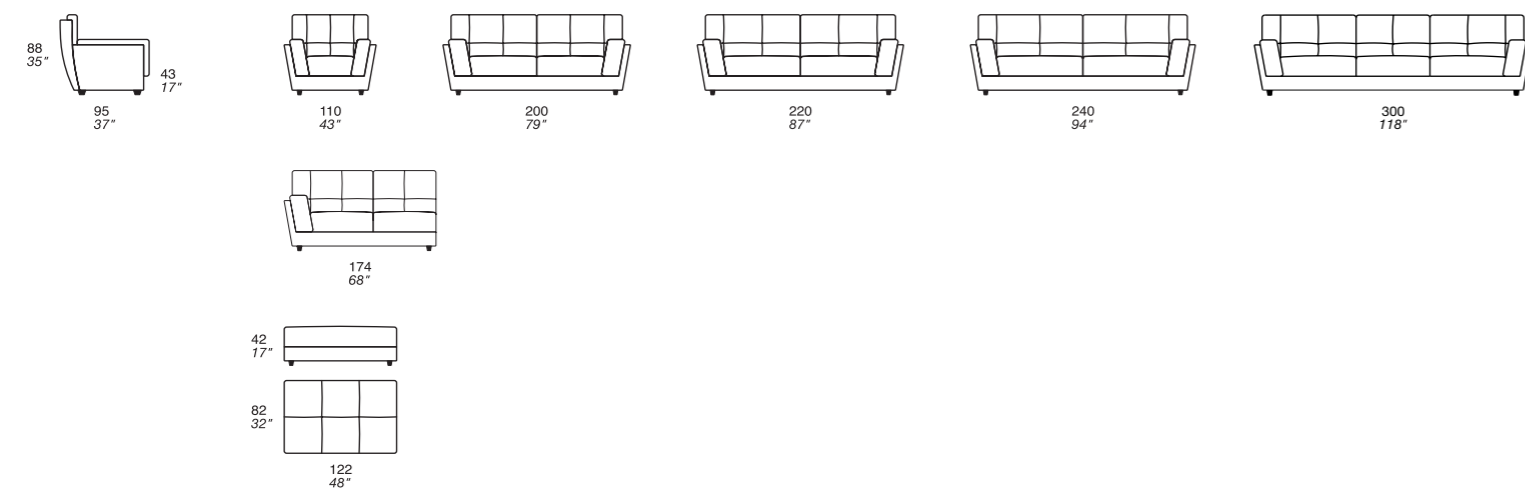

– MALAGA

design Rodolfo Bertozzi

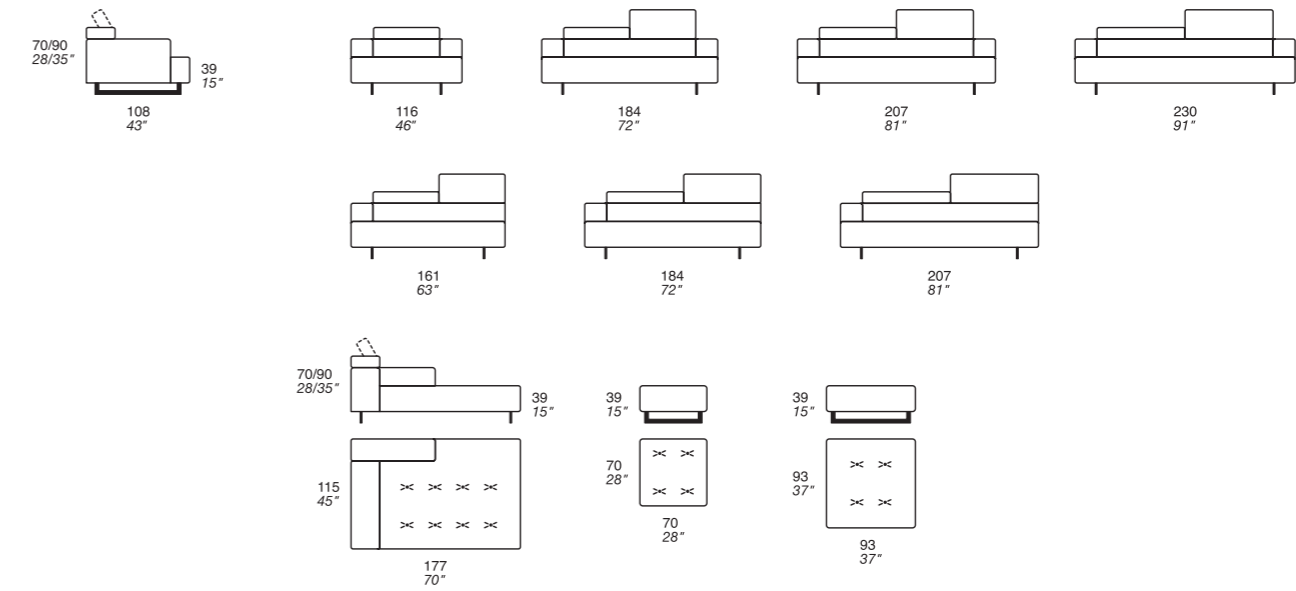

– MAYA

design Style Department Prianera

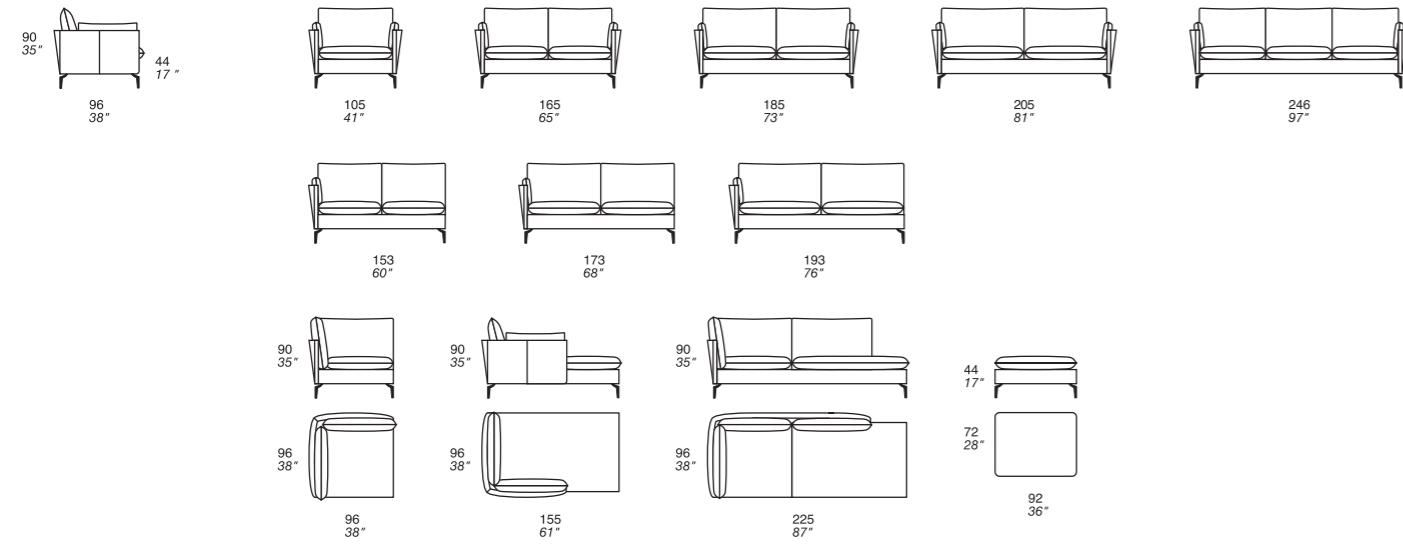

– MOOD

design Fabrizio Ballardini

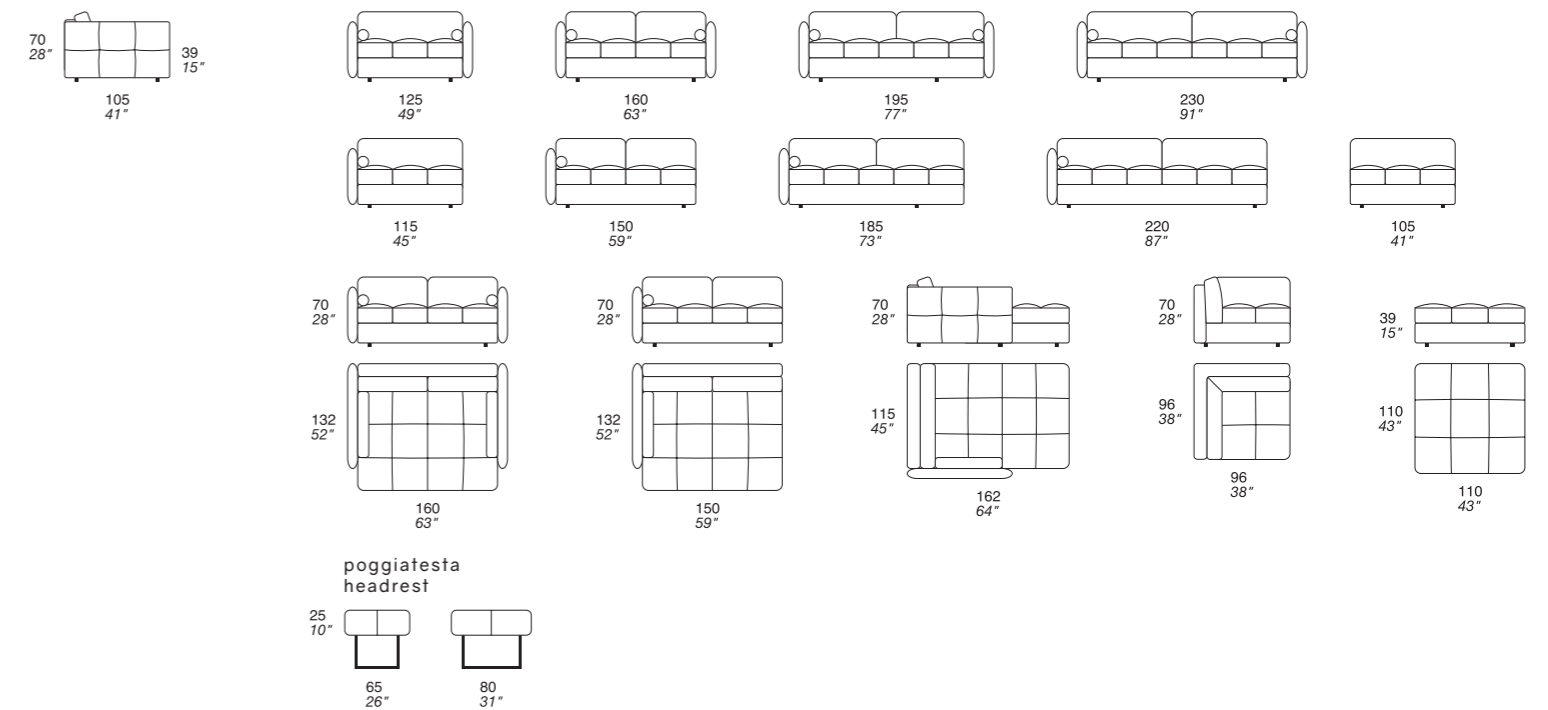

– MODÌ

design Style Department Prianera

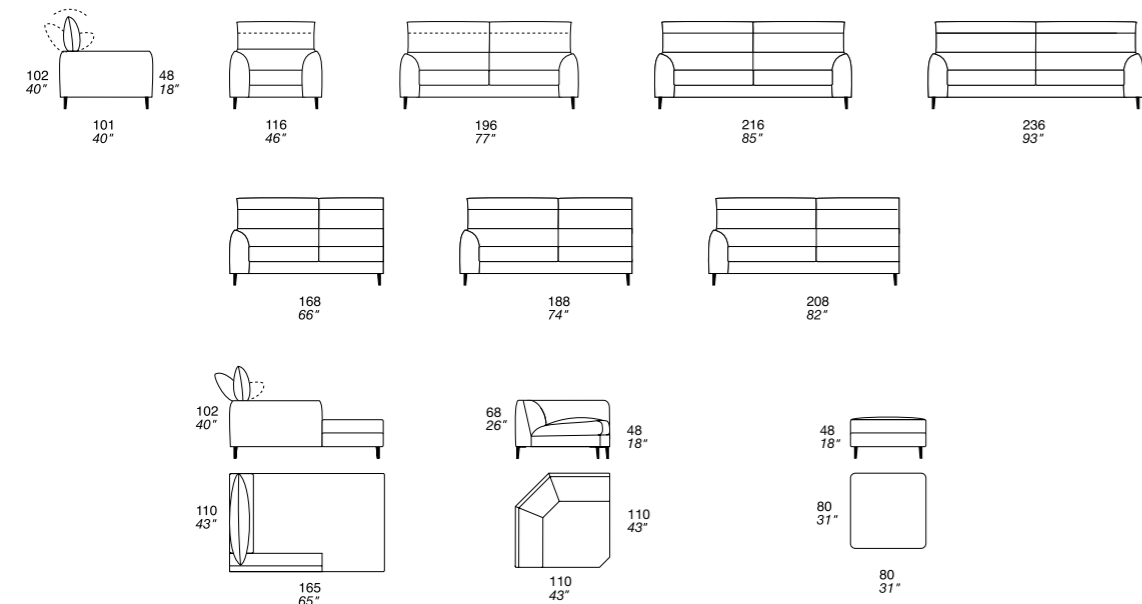

– NESTING

design Enrico Cesana

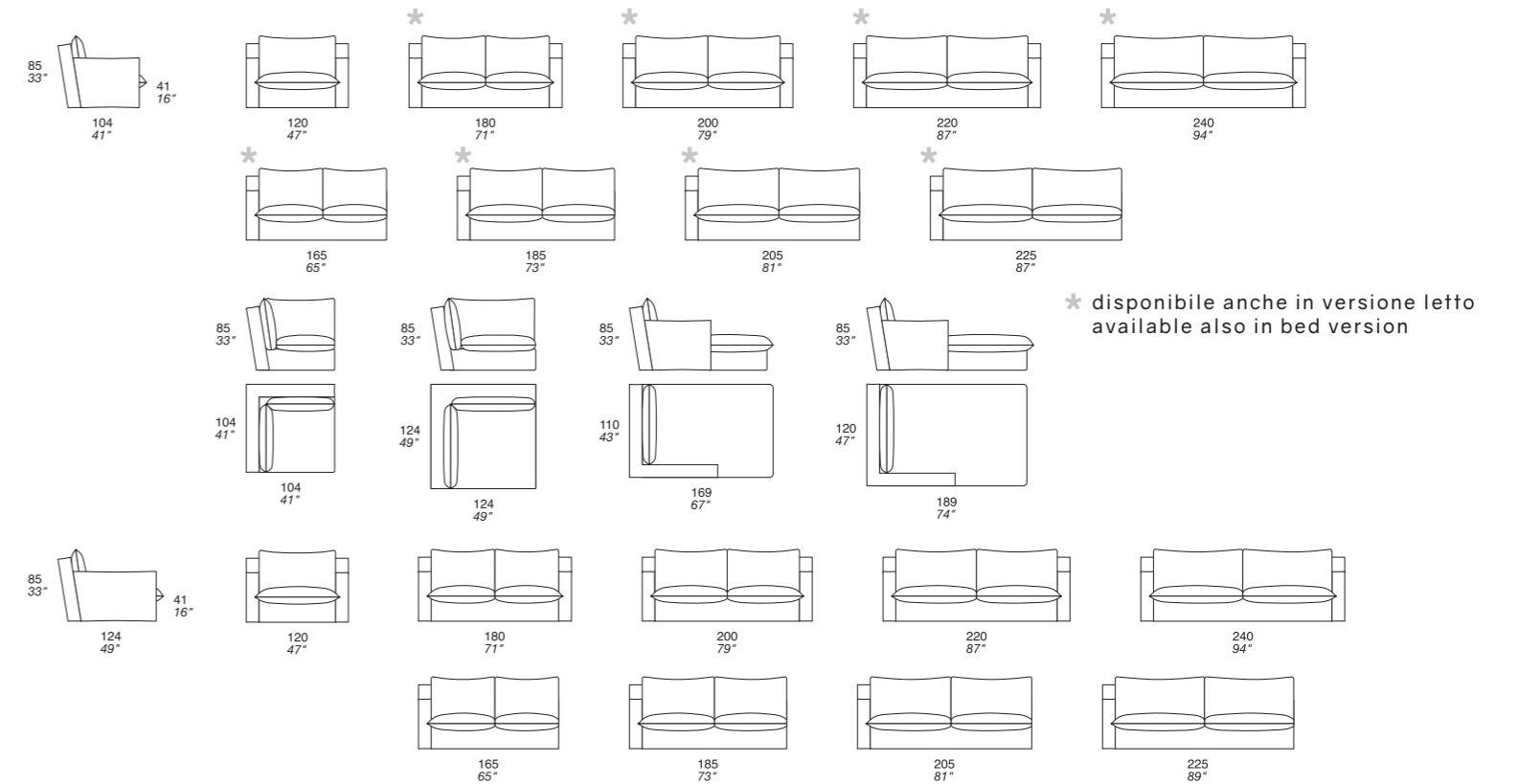

– ODEON

design Giorgio Ragazzini

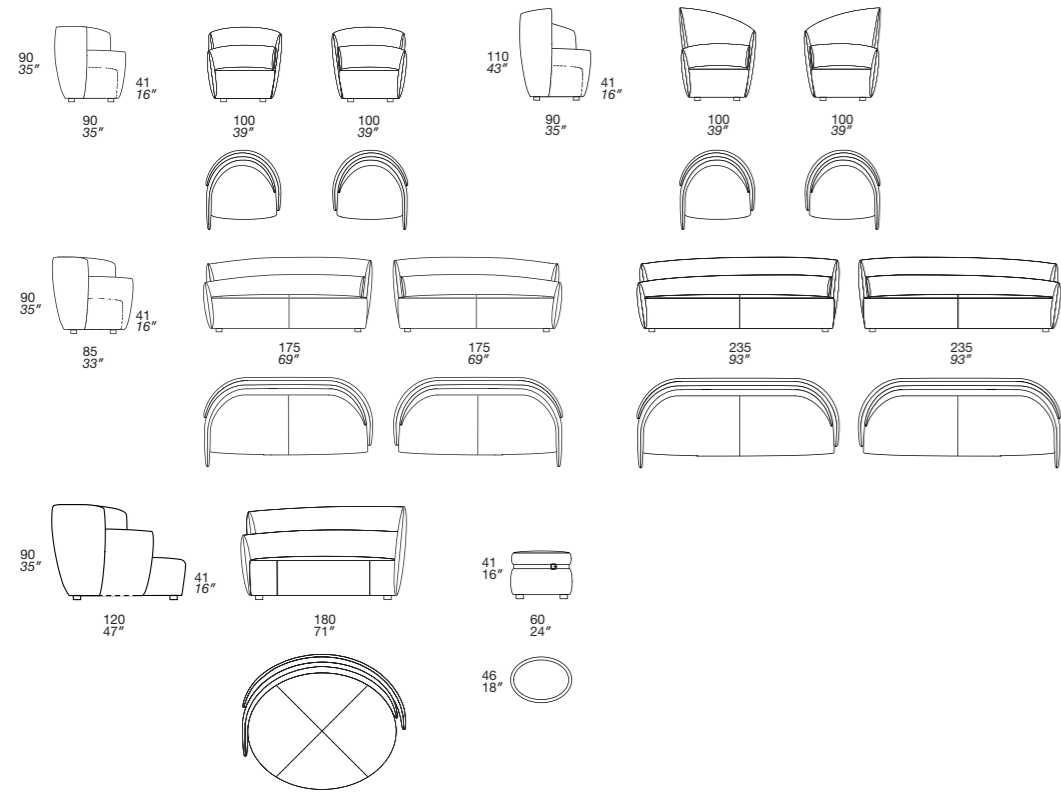

– PALCO

design Giorgio Ragazzini

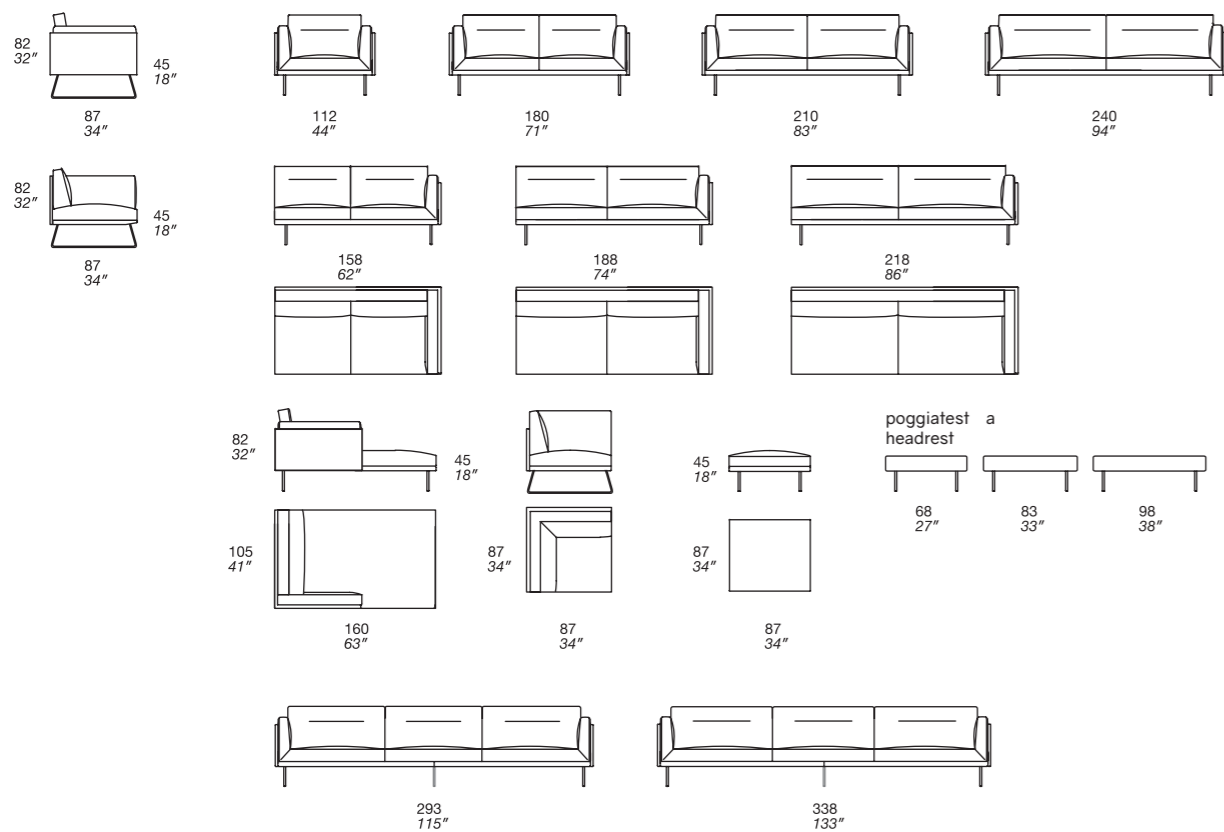

– POOK

design Fabrizio Ballardini

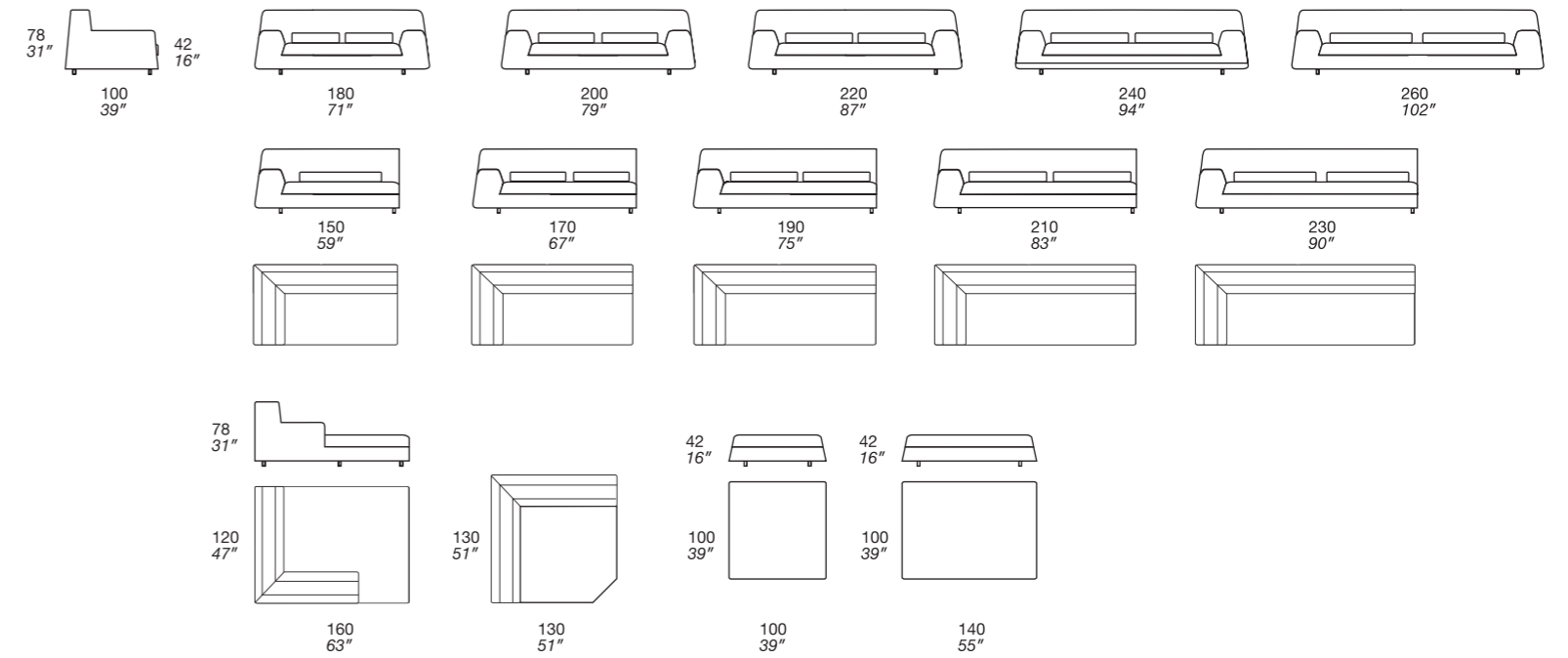

– SHARPEI

design Fabrizio Ballardini

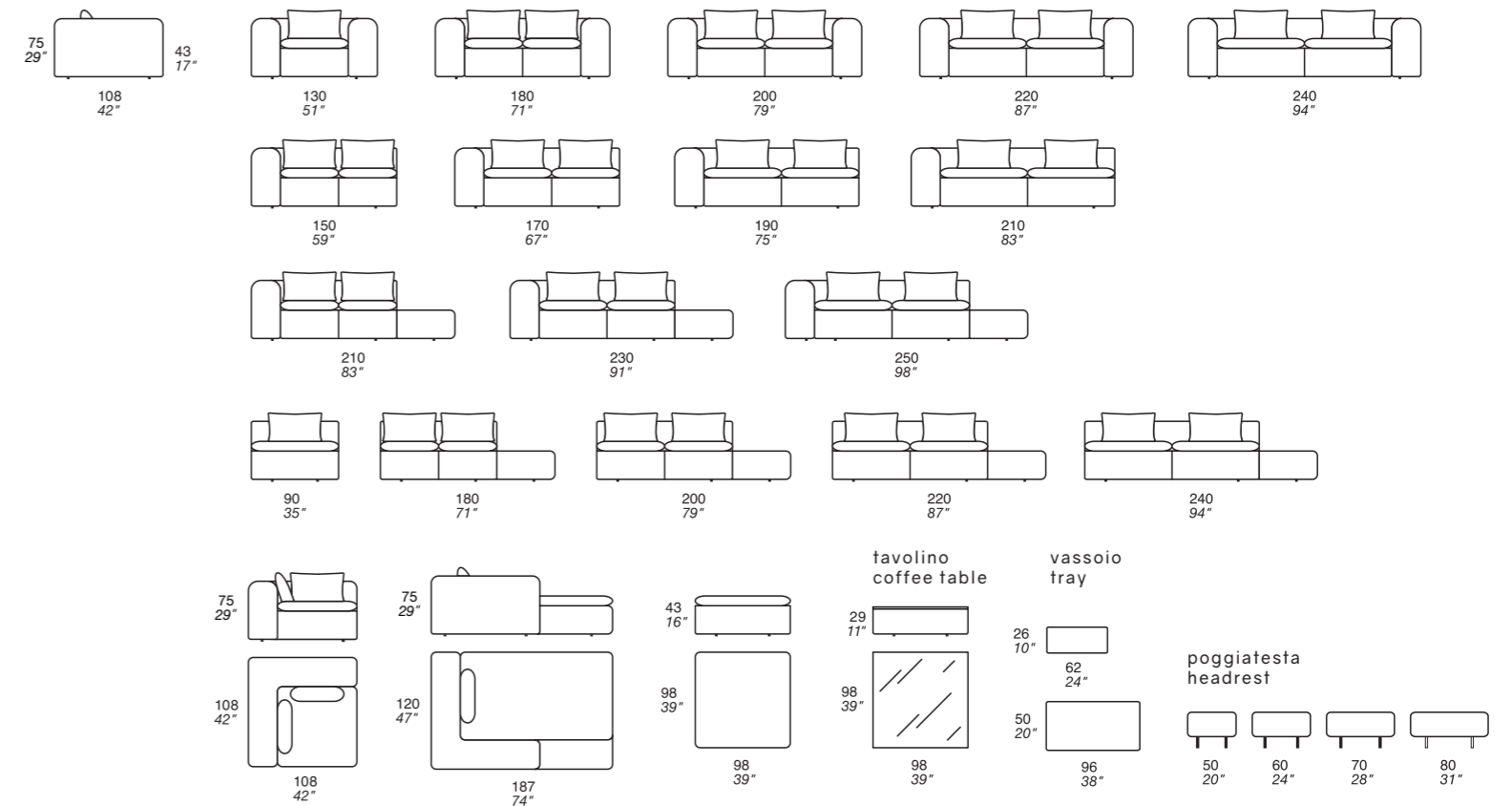

– SONORA

design Fabrizio Ballardini

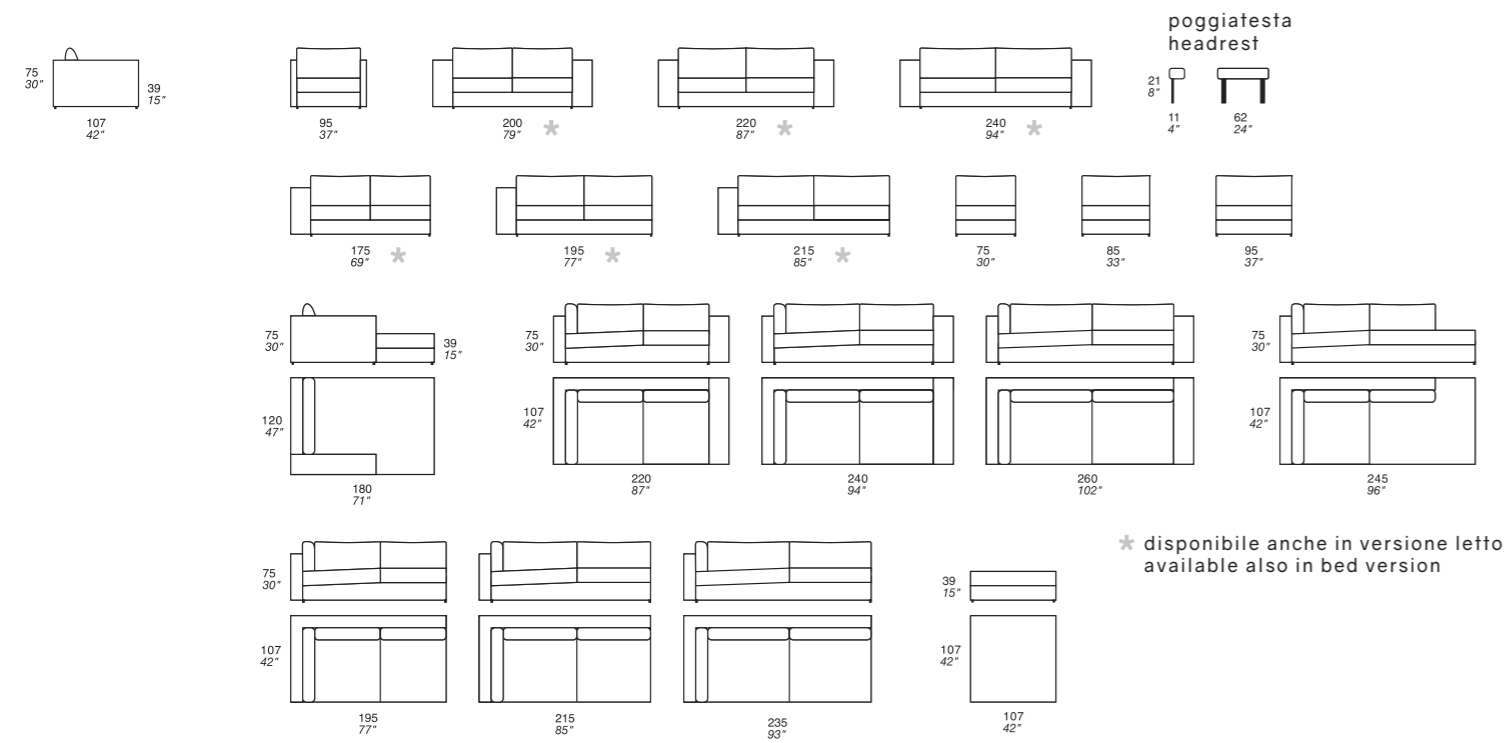

– TANGRAM UP

design Enrico Cesana

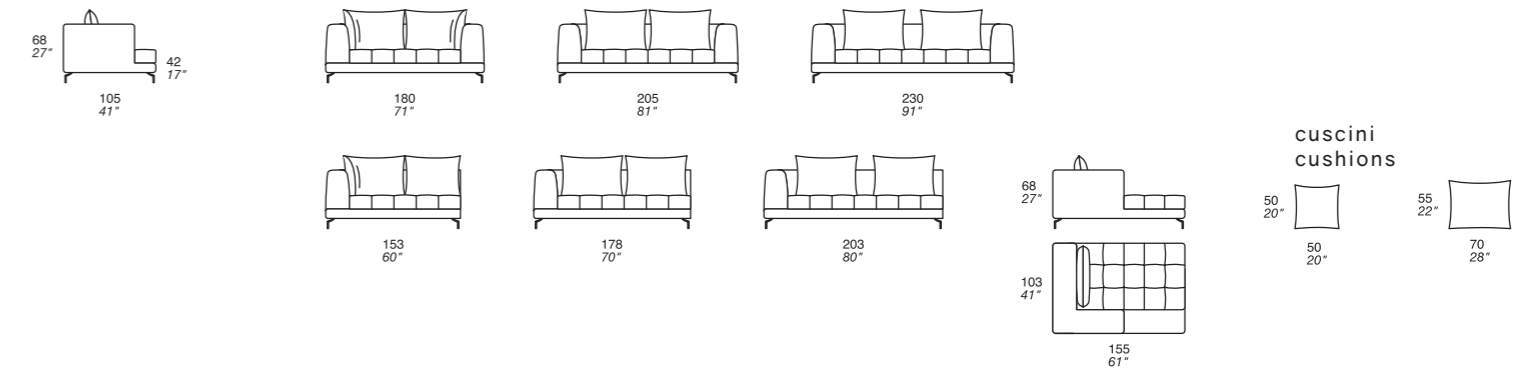

– SORRENTINO

design Style Department Prianera

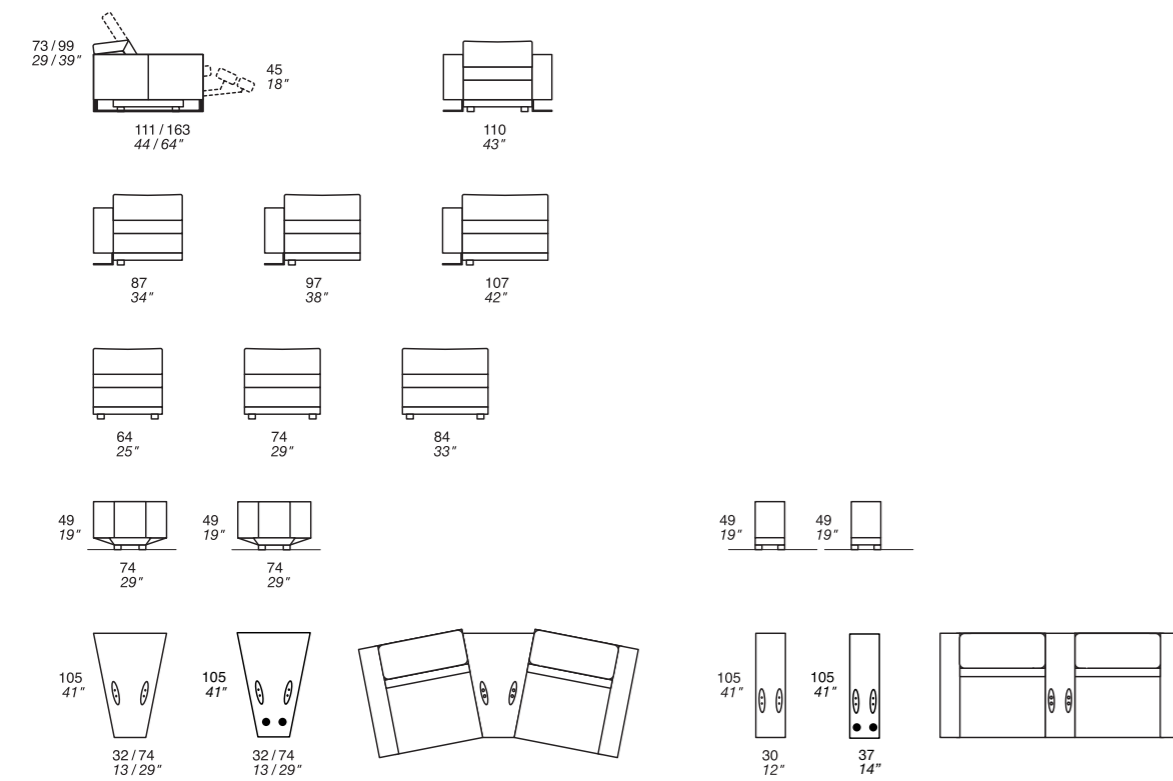

– TOSCA

design Carlo Bimbi

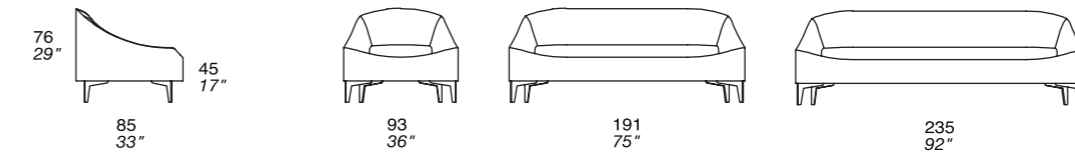

– ALICE

design Carlo Bimbi

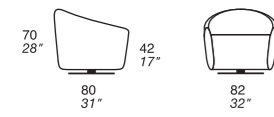

– FLORENCE

design Style Department Prianera

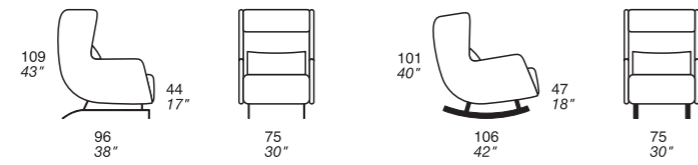

– BLENDY

design Giorgio Ragazzini

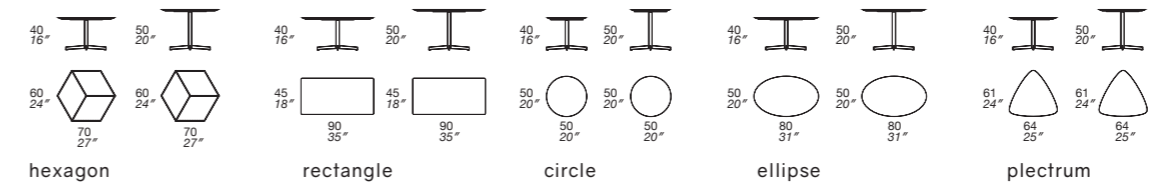

– KAREN

design Carlo Bimbi

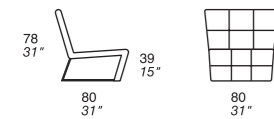

– KLAB

design Carlo Bimbi

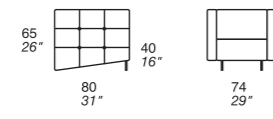

– LOTO

design Carlo Bimbi

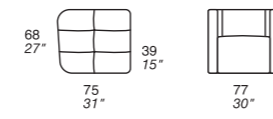

– I PIANI

design Rino Dalmonte

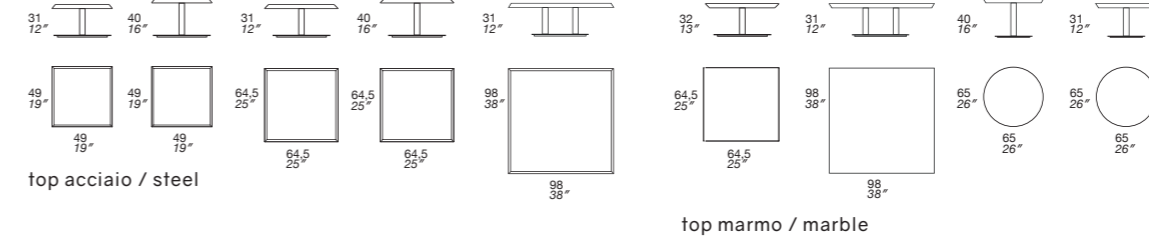

– MINIPOOK

design Fabrizio Ballardini

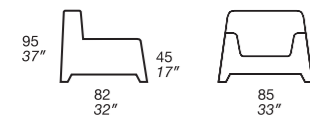

– NORA

design Fabrizio Ballardini

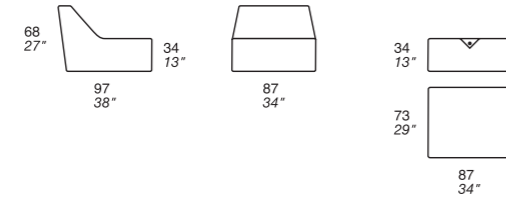

– MAX

design Carlo Bimbi

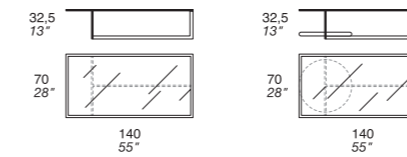

– MEMPHIS

design Style Department Prianera

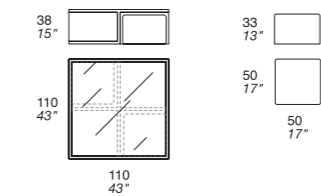

– TRIAL

design Carlo Bimbi

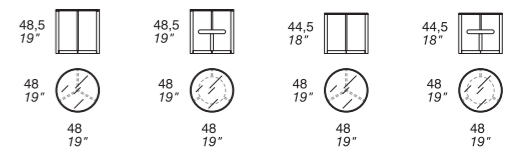

– WEBY

design Fabrizio Ballardini

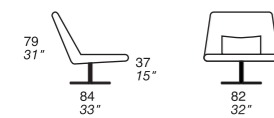

– ZOE

design Carlo Bimbi & Carlo Sironi

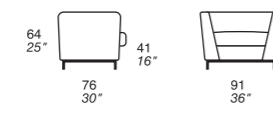

– TRIBAS

design Carlo Bimbi

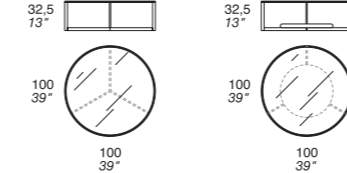

– COFFEE SAK & POUF SAK

design Fabrizio Ballardini

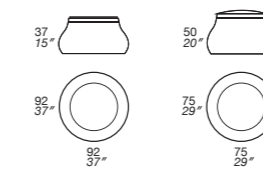

– PASSEPARTOUT

design Giorgio Ragazzini

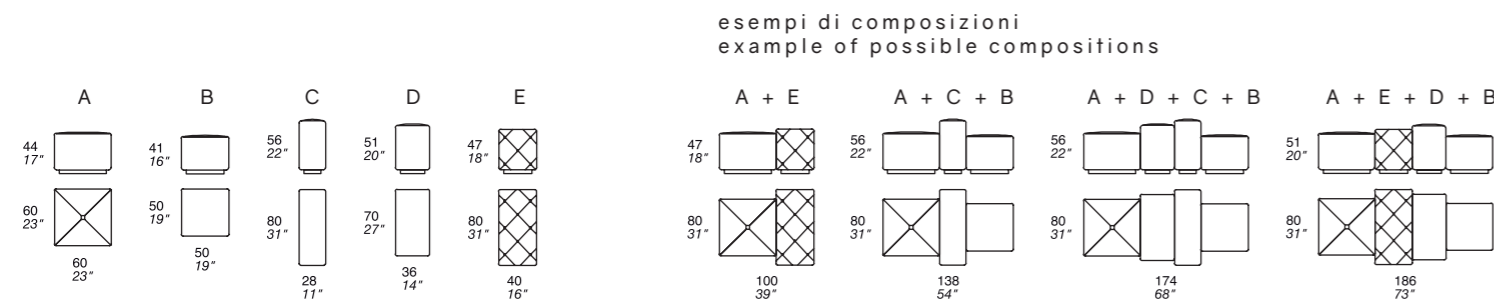

– MEDEA

design Giorgio Ragazzini

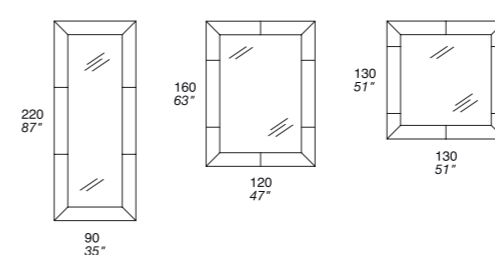

– VIVIAN

design Giorgio Ragazzini

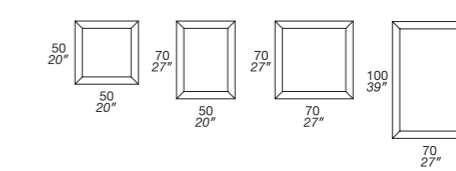

– COLOPHON

project coordination | **Andrea Rasi**

art direction & graphic design | **Studio Giorgio Ragazzini**

photography | **Studio Aeroplano - Giovanni Collina**

prepress | **Studio 59 Prepress**

print | **Modulgrafica Forlivese**

www.prianera.it | info@prianera.it

L'azienda si riserva di apportare modifiche che ritiene più opportune ai prodotti, in qualsiasi momento e senza preavviso. Alcuni accessori presenti nelle immagini fotografiche non sono prodotti dalla ditta Designed for living srl, si prega di far sempre riferimento al listino prezzi. È vietata ogni riproduzione totale o parziale in Italia e all'estero.

Designed for living srl reserves the right to modify models and dimensions without any previous notice. Some accessories present in the photographs are not produced by Designed for living srl, please refer to price list. Total or partial reproduction prohibited in Italy or any other country.

PRIANERA®

DESIGNED FOR LIVING SRL

via Bernardo Dovizi, 6 Forlì (FC) 47122 Italy

tel +39 0543 1716055 fax +39 0543 1716073